



# COMBIVERT S6

INSTRUCTIONS FOR USE | INSTALLATION S6 HOUSING 2

Translation of the original manual  
Document 20088319 EN 11



# Preface

The hardware and software described in this document are products of KEB. The information contained in this document is valid at the time of publishing. KEB reserves the right to update this document in response to misprints, mistakes or technical changes.

## Signal words and symbols

Certain procedures within this document can cause safety hazards during the installation or operation of the device. Refer to the safety warnings in this document when performing these procedures. Safety signs are also located on the device where applicable. A safety warning is marked by one of the following warning signs:

<b>DANGER</b>	Dangerous situation, which will cause death or serious injury if this safety warning is ignored.
<b>WARNING</b>	Dangerous situation, which may cause death or serious injury if this safety warning is ignored.
<b>CAUTION</b>	Dangerous situation, which may cause minor injury if this safety warning is ignored.
<b>NOTICE</b>	Situation, which can cause damage to property if this safety warning is ignored.

### RESTRICTION

Used when the following statements depend on certain conditions or are only valid for certain ranges of values.



Used for informational messages or recommended procedures.

## More symbols

- ▶ This arrow starts an action step.
- / - Enumerations are marked with dots or indents.
- => Cross reference to another chapter or another page.



Note to further documentation.  
[www.keb.de/service/downloads](http://www.keb.de/service/downloads)



## Laws and guidelines

KEB Automation KG confirms with the EC declaration of conformity and the CE mark on the device nameplate that it complies with the essential safety requirements.

The EC declaration of conformity can be downloaded on demand via our website. Further information is provided in chapter "Certification".

## Warranty and liability

The warranty and liability on design, material or workmanship for the acquired device is given in the general sales conditions.



Here you will find our general sales conditions.  
[www.keb.de/terms-and-conditions](http://www.keb.de/terms-and-conditions)



Further agreements or specifications require a written confirmation.

## Support

Although multiple applications are referenced, not every case has been taking into account. If you require further information or if problems occur which are not referenced in the documentation, you can request the necessary information via the local KEB agency.

**The use of our units in the target products is outside of our control and therefore lies exclusively in the area of responsibility of the customer.**

The information contained in the technical documentation, as well as any user-specific advice in spoken and written and through tests, are made to best of our knowledge and information about the intended use. However, they are regarded as being only informal and changes are expressly reserved, in particular due to technical changes. This also applies to any violation of industrial property rights of a third-party. Selection of our units in view of their suitability for the intended use must be done generally by the user.

**Tests can only be done within the intended end use of the product (application) by the customer. They must be repeated, even if only parts of hardware, software or the unit adjustment are modified.**

## Copyright

The customer may use the instructions for use as well as further documents or parts from it for internal purposes. Copyrights are with KEB and remain valid in its entirety.

This KEB product or parts thereof may contain third-party software, including free and/or open source software. If applicable, the license terms of this software are contained in the instructions for use. The instructions for use are already available to you, can be downloaded free of charge from the KEB website or can be requested from the respective KEB contact person.

Other wordmarks or/and logos are trademarks (™) or registered trademarks (®) of their respective owners.

# Table of Contents

<b>Preface</b> .....	<b>3</b>
Signal words and symbols .....	3
More symbols.....	3
Laws and guidelines.....	4
Warranty and liability.....	4
Support .....	4
Copyright.....	4
<b>Table of Contents</b> .....	<b>5</b>
<b>List of Figures</b> .....	<b>9</b>
<b>List of Tables</b> .....	<b>10</b>
<b>Glossary</b> .....	<b>11</b>
<b>Standards for drive converters/control cabinets</b> .....	<b>13</b>
Product standards that apply directly to the drive converter .....	13
Basic standards to which drive converter standards refer directly .....	13
Standards that are used in the environment of the drive converter .....	14
<b>1 Basic Safety Instructions</b> .....	<b>15</b>
1.1 Target group.....	15
1.2 Transport, storage and proper use .....	15
1.3 Installation.....	16
1.4 Electrical connection .....	17
1.4.1 EMC-compatible installation.....	18
1.4.2 Voltage test.....	18
1.4.3 Insulation measurement.....	18
1.5 Start-up and operation .....	19
1.6 Maintenance.....	20
1.7 Repair .....	21
1.8 Disposal.....	21
<b>2 Product Description</b> .....	<b>22</b>
2.1 Specified application.....	22
2.1.1 Residual risks .....	22
2.2 Unintended use.....	22
2.3 Product features .....	23
2.4 Type code .....	24
2.5 Nameplate .....	25
2.5.1 Configurable options .....	26
<b>3 Technical Data</b> .....	<b>27</b>
3.1 Operating conditions .....	27
3.1.1 Climatic environmental conditions.....	27
3.1.2 Mechanical environmental conditions .....	28

3.1.3 Chemical / mechanical active substances.....	28
3.1.4 Electrical operating conditions.....	29
3.1.4.1 Device classification.....	29
3.1.4.2 Electromagnetic compatibility.....	29
<b>3.2 Dimensions and weights .....</b>	<b>30</b>
3.2.1 Built-in version.....	30
3.2.2 Control cabinet installation .....	31
<b>3.3 Mounting instructions for control cabinet installation .....</b>	<b>32</b>
3.3.1 Installation depth .....	33
<b>3.4 Device data of the 400 V devices.....</b>	<b>34</b>
3.4.1 Overview of the 400 V devices .....	34
3.4.2 Rated operation.....	34
3.4.3 Voltage and frequency specifications of the 400 V devices .....	35
3.4.3.1 Example for the calculation of the motor voltage .....	35
3.4.4 Input and output currents / overload of the 400 V devices.....	36
<b>3.5 Device data of the 230 V devices .....</b>	<b>37</b>
3.5.1 Overview of the 230 V devices .....	37
3.5.2 Rated operation.....	37
3.5.3 Voltage and frequency specifications of the 230 V devices .....	38
3.5.4 Input and output currents / overload of the 230 V devices.....	39
<b>3.6 General data.....</b>	<b>40</b>
3.6.1 Overload characteristic (OL) .....	40
3.6.1.1 Switch-off time depending on the overload at 400 V devices .....	41
3.6.1.2 Switch-off time depending on the overload at 230 V devices .....	42
3.6.1.3 Maximum current (OL2) .....	43
3.6.2 Switching frequency and temperature.....	46
3.6.3 Protection of the drive controller.....	47
3.6.3.1 400V units, 3-phase .....	47
3.6.3.2 230V devices, 1-phase .....	47
3.6.4 DC link / braking transistor function.....	48
3.6.4.1 DC link / braking transistor function of the 400V devices .....	48
3.6.4.2 DC link / braking transistor function of the 230V devices .....	48
3.6.5 Power dissipation 400V devices .....	49
3.6.6 Power dissipation 230V devices .....	49
3.6.7 Fan .....	50
3.6.7.1 Switching behaviour of the fan .....	50
3.6.7.2 Switching points of the fan .....	50
<b>4 Installation and Connection.....</b>	<b>51</b>
<b>4.1 Overview of the COMBIVERT S6.....</b>	<b>51</b>
<b>4.2 Connection of the power unit.....</b>	<b>53</b>
4.2.1 Connection of the voltage supply .....	53
4.2.1.1 400V devices .....	53

4.2.1.2 230V devices .....	53
4.2.1.3 Mains terminal block X1A.....	54
4.2.2 Leakage currents.....	55
4.2.3 Protective earth and functional earth.....	55
4.2.3.1 Protective earth .....	55
4.2.3.2 Functional earthing.....	56
4.2.4 AC connection .....	57
4.2.4.1 AC supply 230V/400V 3-phase.....	57
4.2.4.2 AC supply 230V 1-phase .....	58
4.2.4.3 Supply cable.....	59
4.2.5 DC connection.....	59
4.2.5.1 Connection at DC voltage supply .....	59
4.2.5.2 Terminal block X1B DC connection .....	59
4.2.6 Connection of the motor .....	60
4.2.6.1 Selection of the motor cable.....	60
4.2.6.2 Cable-fed disturbances depending on the motor cable length at AC supply.....	60
4.2.6.3 Motor cable length at operation with DC voltage.....	60
4.2.6.4 Motor cable length for parallel operation of motors .....	61
4.2.6.5 Motor cable cross-section .....	61
4.2.6.6 Interconnection of the motor.....	61
4.2.6.7 Terminal block X1B motor connection .....	61
4.2.6.8 Wiring of the motor .....	62
4.2.7 Connection of a braking resistor.....	63
4.2.7.1 Terminal block X1B connection braking resistor.....	63
4.2.7.2 Use of intrinsically safe braking resistors .....	63
4.2.7.3 Use of non-intrinsically safe braking resistors .....	64
<b>4.3 Brake control and temperature detection for K- and A- control .....</b>	<b>65</b>
4.3.1 Specification and connection of the brake control.....	65
4.3.2 Specification and connection of the temperature detection.....	66
4.3.3 Operation without temperature detection .....	67
4.3.4 Connection of a KTY sensor .....	67
4.3.5 Connection of PTC, temperature switch or PT1000.....	68
<b>4.4 Brake control and temperature detection for P- control.....</b>	<b>69</b>
4.4.1 Specification and connection of the brake / relay control.....	69
4.4.2 Specification and connection of the temperature detection.....	70
4.4.2.1 Operation without temperature detection .....	71
4.4.2.2 Connection of a KTY sensor .....	71
4.4.2.3 Connection of PTC, temperature switch or PT1000.....	72

<b>5 Certification.....</b>	<b>73</b>
5.1 CE-Marking.....	73
5.2 Functional safety .....	73
5.3 Annex to the declaration of conformity.....	73
5.4 UL Marking .....	75
5.5 Further informations and documentation .....	78
<b>6 Revision History .....</b>	<b>79</b>



## List of Figures

Figure 1:	Nameplate.....	25
Figure 2:	Dimensions built-in version housing 2 .....	30
Figure 3:	Mounting distances .....	31
Figure 4:	Control cabinet ventilation.....	31
Figure 5:	Installation depth.....	33
Figure 6:	Switch-off time $t$ depending on the overload $I/IN$ (OL) 400 V devices .....	41
Figure 7:	Switch-off time $t$ depending on the overload $I/IN$ (OL) 230 V devices .....	42
Figure 8:	Overload characteristic in the lower speed range (OL2).....	43
Figure 9:	Block diagram of the energy flow.....	49
Figure 10:	Switching behaviour of the fan.....	50
Figure 11:	Overview COMBIVERT S6 .....	51
Figure 12:	Input circuit/drive controller type 400 V devices .....	53
Figure 13:	Input circuit/drive controller type 230 V devices .....	53
Figure 14:	Mains terminal block X1A.....	54
Figure 15:	Connection for protective earth.....	55
Figure 16:	Connection of the mains supply 3-phase devices .....	57
Figure 17:	Connection of the mains supply 1-phase devices .....	58
Figure 18:	Connection at DC voltage supply.....	59
Figure 19:	Terminal block X1B DC connection.....	59
Figure 20:	Terminal block X1B motor connection.....	61
Figure 21:	Wiring of the motor.....	62
Figure 22:	Terminal block X1B connection braking resistor .....	63
Figure 23:	Wiring of an intrinsically safe braking resistor.....	63
Figure 24:	Assignment of the terminal block X1C for K- and A-control .....	65
Figure 25:	Example for the connection of the brake output at X1C .....	65
Figure 26:	Connection of a KTY sensor for K- and A-control .....	67
Figure 27:	Connection examples of different temperature sensors K/A.....	68
Figure 28:	Assignment of the terminal block X1C for P-control .....	69
Figure 29:	Connection of a KTY sensor for P-control .....	71
Figure 30:	Connection examples of different temperature sensors for P-control .....	72

## List of Tables

Table 1:	Type code .....	24
Table 2:	Configurable options .....	26
Table 3:	Climatic environmental conditions .....	27
Table 4:	Mechanical environmental conditions .....	28
Table 5:	Chemical / mechanical active substances .....	28
Table 6:	Device classification.....	29
Table 7:	Electromagnetic compatibility .....	29
Table 8:	Mounting instructions for control cabinet installation .....	32
Table 9:	Overview device data of the 400 V devices .....	34
Table 10:	Input voltages and frequencies of the 400 V devices .....	35
Table 11:	Input voltages for DC operation of the 400 V devices .....	35
Table 12:	Output voltages and frequencies of the 400 V devices .....	35
Table 13:	DC switching level 400V devices .....	35
Table 14:	Example for the calculation of the motor voltage .....	35
Table 15:	Input currents of the 400 V devices.....	36
Table 16:	Output currents of the 400V devices .....	36
Table 17:	Overview device data of the 230V devices .....	37
Table 18:	Input voltages and frequencies of the 230 V devices .....	38
Table 19:	Input voltages for DC operation of the 230 V devices .....	38
Table 20:	Output voltages and frequencies of the 230 V devices .....	38
Table 21:	DC switching level of the 230V devices .....	38
Table 22:	Input currents of the 230V devices.....	39
Table 23:	Output currents of the 230V devices .....	39
Table 24:	Frequency-dependent maximum current for device size 07 400 V devices.....	44
Table 25:	Frequency-dependent maximum current for device size 09 400 V devices.....	44
Table 26:	Frequency-dependent maximum current for device size 10 400 V devices.....	44
Table 27:	Frequency-dependent maximum current for device size 07 230 V devices.....	45
Table 28:	Frequency-dependent maximum current for device size 09 230 V devices.....	45
Table 29:	Switching frequency and temperature .....	46
Table 30:	Fusing of the drive controllers 400 V devices, 3-phase .....	47
Table 31:	Fusing of the drive controllers 230V devices, 1-phase.....	47
Table 32:	DC link / braking transistor function of the 400 V devices .....	48
Table 33:	DC link / braking transistor function of the 230 V devices .....	48
Table 34:	Power dissipation 400V devices.....	49
Table 35:	Power dissipation 230V devices.....	49
Table 36:	Leakage currents 1-phase .....	55
Table 37:	Leakage currents 3-phase .....	55
Table 38:	Maximum motor cable length at AC supply.....	60
Table 39:	Maximum motor cable length at DC operation.....	60
Table 40:	Specification of the temperature input for K- and A-control .....	66
Table 41:	Specification of the brake control for P-control .....	69
Table 42:	Specification of the temperature input for P-control.....	70
Table 43:	Applied standards .....	74

## Glossary

0V	Earth-potential-free common point	Endat	Bidirectional encoder interface of the company Heidenhain
1ph	1-phase mains	EtherCAT	Real-time Ethernet bus system of the company Beckhoff
3ph	3-phase mains	Ethernet	Real-time bus system - defines protocols, plugs, types of cables
AC	AC current or voltage	FE	Functional earth
AFE	From 07/2019 AIC replaces the previous name AFE	FSoE	Functional Safety over Ethernet
AFE filter	From 07/2019 AIC filter replaces the previous name AFE filter	FU	Drive converter
AIC	Active Infeed Converter	GND	Reference potential, ground
AIC filter	Filter for Active Infeed Converter	GTR7	Braking transistor
Application	The application is the intended use of the KEB product	HF filter	High frequency filter to the mains
ASCL	Asynchronous sensorless closed loop	Hiperface	Bidirectional encoder interface of the company Sick-Stegmann
Auto motor ident.	Automatically motor identification; calibration of resistance and inductance	HMI	Human machine interface (touch screen)
AWG	American wire gauge	HSP5	Fast, serial protocol
B2B	Business-to-business	HTL	Incremental signal with an output voltage (up to 30V) -> TTL
BiSS	Open source real-time interface for sensors and actuators (DIN 5008)	IEC	International standard
CAN	Fieldbus system	IP xx	Degree of protection (xx for level)
CDF	Cyclic duration factor	KEB product	The KEB product is subject of this manual
CDM	Complete drive module including auxiliary equipment (control cabinet)	KTY	Silicium temperature sensor (polarized)
COMBIVERT	KEB drive converters	Manufacturer	The manufacturer is KEB, unless otherwise specified (e.g. as manufacturer of machines, engines, vehicles or adhesives)
COMBIVIS	KEB start-up and parameterizing software	MCM	American unit for large wire cross sections
Customer	The customer has purchased a KEB product from KEB and integrates the KEB product into his product (customer product) or resells the KEB product (dealer)	Modulation	Means in drive technology that the power semiconductors are controlled
DC	DC current or voltage	MTTF	Mean service life to failure
DI	Demineralized water, also referred to as deionized (DI) water	NN	Sea level
DIN	German Institut for standardization	OC	Overcurrent
DS 402	CiA DS 402 - CAN device profile for drives	OH	Overheat
EMC	Electromagnetic compatibility	OL	Overload
Emergency stop	Shutdown of a drive in emergency case (not de-energized)	OSSD	Output signal swithcing device; - an output signal that is checked in regular intervals on its shutdown. (safety technology)
Emergency switching off	Switching off the voltage supply in emergency case	PDS	Power drive system incl. motor and measuring probe
EMS	Energy Management System	PE	Protective earth
EN	European standard	PELV	Protective Extra Low Voltage
Encoder emulation	Software-generated encoder output	PFD	Term used in the safety technology (EN 61508-1...7) for the size of error probability
End customer	The end customer is the user of the customer product		

## GLOSSARY

PFH	Term used in the safety technology (EN 61508-1...7) for the size of error probability per hour
PLC	Programmable logic controller
PT100	Temperature sensor with $R_0=100\Omega$
PT1000	Temperature sensor with $R_0=1000\Omega$
PTC	PTC-resistor for temperature detection
PWM	Pulse width modulation
RJ45	Modular connector with 8 lines
SCL	Synchronous sensorless closed loop
SELV	Safety Extra Low Voltage (<60V)
SIL	The security integrity level is a measure for quantifying the risk reduction. Term used in the safety technology (EN 61508 -1...7)
SS1	Safety function „Safe stop 1“ in accordance with IEC 61800-5-2
SSI	Synchronous serial interface for encoder
STO	Safety function „Safe Torque Off“ in accordance with IEC 61800-5-2
TTL	Incremental signal with an output voltage up to 5V
USB	Universal serial bus
VARAN	Real-time Ethernet bus system

## Standards for drive converters / control cabinets

### Product standards that apply directly to the drive converter

EN61800-2	Adjustable speed electrical power drive systems - Part 2: General requirements - Rating specifications for low voltage adjustable frequency a.c. power drive systems (VDE 0160-102, IEC 61800-2)
EN61800-3	Speed-adjustable electrical drives. Part 3: EMC requirements and specific test methods (VDE 0160-103, IEC 61800-3)
EN61800-5-1	Adjustable speed electrical power drive systems - Part 5-1: Safety requirements - Electrical, thermal and energy (IEC 61800-5-1); German version EN 61800-5-1
EN61800-5-2	Adjustable speed electrical power drive systems - Part 5-2: Safety Requirements - Functional (IEC 22G/264/CD)
UL61800-5-1	American version of the EN61800-5-1 with „National Deviations“

### Basic standards to which drive converter standards refer directly

EN 55011	Industrial, scientific and medical equipment - Radio frequency disturbance characteristics - Limits and methods of measurement (CISPR 11); German version EN 55011
EN 55021	Interference to mobile radiocommunications in the presence of impulse noise - Methods of judging degradation and measures to improve performance (IEC/ CISPR/D/230/FDIS); German version prEN 55021
EN 60529	Degrees of protection provided by enclosures (IP Code) (IEC 60529)
EN 60664-1	Insulation coordination for equipment within low-voltage systems Part 1: Principles, requirements and tests (IEC 60664-1)
EN 60721-3-1	Classification of environmental conditions - Part 3-1: Classification of groups of environmental parameters and their severities - Section 1: Storage (IEC 60721-3-1); German version EN 60721-3-1
EN 60721-3-2	Classification of environmental conditions - Part 3: Classification of groups of environmental parameters and their severities - Section 2: Transportation and handling (IEC 104/670/CD)
EN 60721-3-3	Classification of environmental conditions - Part 3: Classification of groups of environmental parameters and their severities; section 3: Stationary use at weatherprotected locations; Amendment A2 (IEC 60721-3-3); German version EN 60721-3-3
EN 61000-2-1	Electromagnetic compatibility (EMC) - Part 2: Environment - Section 1: Description of the environment - Electromagnetic environment for low-frequency conducted disturbances and signalling in public power supply systems
EN 61000-2-4	Electromagnetic compatibility (EMC) - Part 2-4: Environment; Compatibility levels in industrial plants for low-frequency conducted disturbances (IEC 61000-2-4); German version EN 61000-2-4
EN 61000-4-2	Electromagnetic compatibility (EMC) - Part 4-2: Testing and measurement techniques - Electrostatic discharge immunity test (IEC 61000-4-2); German version EN 61000-4-2
EN 61000-4-3	Electromagnetic compatibility (EMC) - Part 4-3: Testing and measurement techniques - Radiated, radio-frequency, electromagnetic field immunity test (IEC 61000-4-3); German version EN 61000-4-3
EN 61000-4-4	Electromagnetic compatibility (EMC) - Part 4-4: Testing and measurement techniques - Electrical fast transient/burst immunity test (IEC 61000-4-4); German version EN 61000-4-4

## STANDARDS FOR DRIVE CONVERTERS/CONTROL CABINETS

EN61000-4-5	Electromagnetic compatibility (EMC) - Part 4-5: Testing and measurement techniques - Surge immunity test (IEC 61000-4-5); German version EN 61000-4-5
EN61000-4-6	Electromagnetic compatibility (EMC) - Part 4-6: Testing and measurement techniques - Immunity to conducted disturbances, induced by radio-frequency fields (IEC 61000-4-6); German version EN 61000-4-6
EN61000-4-34	Electromagnetic compatibility (EMC) - Part 4-34: Testing and measurement techniques - Voltage dips, short interruptions and voltage variations immunity tests for equipment with mains current more than 16 A per phase (IEC 61000-4-34); German version EN 61000-4-34
EN61508-1...7	Functional safety of electrical/electronic/programmable electronic safety-related systems – Part 1...7 (VDE 0803-1...7, IEC 61508-1...7)
EN62061	Safety of machinery - functional safety of electrical, electronic and programmable electronic safety-related systems (VDE 0113-50, IEC 62061)
EN ISO 13849-1	Safety of machinery - safety-related parts of control systems - Part 1: General principles for design (ISO 13849-1); German version EN ISO 13849-1

### Standards that are used in the environment of the drive converter

DGUV regulation 3	Electrical installations and equipment
DIN 46228-1	Wire-end ferrules; Tube without plastic sleeve
DIN 46228-4	Wire-end ferrules; Tube with plastic sleeve
DIN IEC 60364-5-54	Low-voltage electrical installations - Part 5-54: Selection and erection of electrical equipment - Earthing arrangements, protective conductors and protective bonding conductors (IEC 64/1610/CD)
DIN VDE 0100-729	Low-voltage electrical installations - Part 7-729: Requirements for special installations or locations - Operating or maintenance gangways (IEC 60364-7-729:2007, modified); German implementation HD 60364-7-729:2009
DNVGL-CG-0339	Environmental test specification for electrical, electronic and programmable equipment and systems
EN 1037	Safety of machinery - Prevention of unexpected start-up; German version EN 1037
EN 12502-1...5	Protection of metallic materials against corrosion - Part 1...5
EN 60204-1	Safety of machinery - electrical equipment of machines Part 1: General requirements (VDE 0113-1, IEC 44/709/CDV)
EN 60439-1	Low-voltage switchgear and controlgear assemblies - Part 1: Type-tested and partially type-tested assemblies (IEC 60439-1); German version EN 60439-1
EN 60947-7-1	Low-voltage switchgear and controlgear - Part 7-1: Ancillary equipment - Terminal blocks for copper conductors (IEC 60947-7-1:2009); German version EN 60947-7-1:2009
EN 60947-8	Low-voltage switchgear and controlgear - Part 8: Control units for built-in thermal protection (PTC) for rotating electrical machines (IEC 60947-8:2003 + A1:2006 + A2:2011)
EN 61373	Railway applications - Rolling stock equipment - Shock and vibration tests (IEC 61373); German version EN 61373
EN 61439-1	Low-voltage switchgear and controlgear assemblies - Part 1: General rules (IEC 121B/40/CDV); German version FprEN 61439-1
VGB R 455 P	Water treatment and use of materials in cooling systems
DIN EN 60939-1	Passive filter units for electromagnetic interference suppression - Part 1: Generic specification (IEC 60939-1:2010); German version EN 60939-1:2010

# 1 Basic Safety Instructions

The COMBIVERT is designed and constructed in accordance with state-of-the-art technology and the recognized safety rules and regulations. However, the use of such devices may cause functional hazards for life and limb of the user or third parties, or damages to the system and other material property.

The following safety instructions have been created by the manufacturer for the area of electric drive technology. They can be supplemented by local, country- or application-specific safety instructions. This list is not exhaustive. Violation of the safety instructions by the customer, user or other third party leads to the loss of all resulting claims against the manufacturer.

## NOTICE



### Hazards and risks through ignorance.

- ▶ Read the instructions for use !
- ▶ Observe the safety and warning instructions !
- ▶ If anything is unclear, please contact KEB Automation KG !

## 1.1 Target group

This instruction manual is determined exclusively for electrical personnel. Electrical personnel for the purpose of this instruction manual must have the following qualifications:

- Knowledge and understanding of the safety instructions.
- Skills for installation and assembly.
- Start-up and operation of the product.
- Understanding of the function in the used machine.
- Detection of hazards and risks of the electrical drive technology.
- Knowledge of *DIN IEC 60364-5-54*.
- Knowledge of national safety regulations.

## 1.2 Transport, storage and proper use

The transport is carried out by qualified persons in accordance with the environmental conditions specified in this manual. Drive converter shall be protected against excessive strains.



### Transport of drive converters with an edge length >75 cm

The transport by forklift without suitable tools can cause a deflection of the heat sink. This leads to premature aging or destruction of internal components.

- ▶ Transport of drive converters on suitable pallets.
- ▶ Do not stack drive converters or burden them with other heavy objects.



---

**Drive converters contain electrostatic sensitive components.**

- ▶ Avoid contact.
  - ▶ Wear ESD-protective clothing.
- 

Do not store drive converters

- in the environment of aggressive and/or conductive liquids or gases.
- with direct sunlight.
- outside the specified environmental conditions.

### 1.3 Installation

**⚠ DANGER**



---

**Do not operate in an explosive environment!**

- ▶ The COMBIVERT is not intended for the use in potentially explosive environment.
- 

**⚠ CAUTION**



---

**Maximum design edges and high weight!**

**Contusions and bruises!**

- ▶ Never stand under suspended loads.
  - ▶ Wear safety shoes.
  - ▶ Secure drive converter accordingly when using lifting gear.
- 

- To prevent damages to the device:
- Make sure that no components are bent and/or isolation distances are changed.
- The device must not be put into operation in case of mechanical defects.
- Do not allow moisture or mist to penetrate the unit.
- Avoid dust permeating the device. Allow for sufficient heat dissipation if installed in a dust-proof housing.
- Note installation position and minimum distances to surrounding elements. Do not cover the ventilation openings.
- Mount the drive inverter according to the specified degree of protection.
- Make sure that no small parts fall into the COMBIVERT during assembly and wiring (drilling chips, screws etc.). This also applies to mechanical components, which can lose small parts during operation.
- Check the reliable fit of the device connections in order to avoid contact resistances and sparking.
- Do not walk-on drive converter.
- Follow all safety instructions!



## 1.4 Electrical connection

### DANGER



#### Voltage at the terminals and in the device!

##### Danger to life due to electric shock !

- ▶ Never work on the open device or never touch exposed parts.
- ▶ For any work on the unit switch off the supply voltage, secure it against switching on and check absence of voltage by measurement.
- ▶ Wait until all drives has been stopped in order that no regenerative energy can be generated.
- ▶ Await capacitor discharge time (5 minutes) if necessary, measure DC voltage at the terminals.
- ▶ If personal protection is required, install suitable protective devices for drive converters.
- ▶ Never bridge upstream protective devices (also not for test purposes).
- ▶ Connect the protective earth conductor always to drive converter and motor.
- ▶ Install all required covers and protective devices for operation.
- ▶ The control cabinet shall be kept closed during operation.
- ▶ Residual current: This product may cause a dc current in the protective earth conductor. When a residual current protective device (RCD) or a residual current monitoring device (RCM) is used for the protection against direct or indirect contact, only a RCD or RCM type B is permitted on the power supply side of this product.
- ▶ Drive converters with a leakage current  $> 3.5 \text{ mA AC}$  current (10 mA DC current) are intended for a stationary connection. Protective earth conductors must be designed in accordance with the local regulations for equipment with high leakage currents according to [EN 61800-5-1](#), [EN 60204-1](#) or [DIN IEC 60364-5-54](#).



If personnel protection is required during installation of the system, suitable protective devices must be used for drive converters.

[www.keb.de/fileadmin/media/Manuals/knowledge/04\\_techinfo/00\\_general/ti\\_rcd\\_0400\\_0002\\_gbr.pdf](http://www.keb.de/fileadmin/media/Manuals/knowledge/04_techinfo/00_general/ti_rcd_0400_0002_gbr.pdf)



Installations which include drive converter shall be equipped with additional control and protective devices in accordance with the relevant applicable safety requirements, e.g. act respecting technical equipment, accident prevention rules etc. They must always be complied with, also for drive converter bearing a CE marking.

For a trouble-free and safe operation, please pay attention to the following instructions:

- The electrical installation shall be carried out in accordance with the relevant requirements.
- Cable cross-sections and fuses must be dimensioned by the user according to the specified minimum/maximum values for the application.
- The wiring must be made with flexible copper cable for a temperature  $> 75^{\circ}\text{C}$ .
- Connection of the drive converter is only permissible on symmetrical networks with a maximum line voltage (L1, L2, L3) with respect to earth (N/PE) of max. 300 V. An isolating transformer must be used for supply networks which exceed this value! In case of non-compliance the control is not longer considered to be a PELV circuit.
- With existing or newly wired circuits the person installing the units or machines must ensure that the PELV requirements are met.
- For drive converters that are not isolated from the supply circuit (in accordance with [EN 60721-3-2](#)) all control lines must be included in other protective measures (e.g. double insulation or shielded, earthed and insulated).
- When using components without isolated inputs/outputs, it is necessary that equipotential bonding exists between the components to be connected (e.g. by the equipotential line). Disregard can cause destruction of the components by equalizing currents.

### 1.4.1 EMC-compatible installation

Observance of the limit values required by EMC law is the responsibility of the customer.



Notes on EMC-compatible installation can be found here.  
[www.keb.de/fileadmin/media/Manuals/emv/0000neb0000.pdf](http://www.keb.de/fileadmin/media/Manuals/emv/0000neb0000.pdf)



### 1.4.2 Voltage test

Testing with AC voltage (in accordance with [EN 60204-1](#) chapter 18.4) may not be executed, since there is danger for the power semiconductors in the drive inverter.



Due to the radio interference suppression capacitors, the test generator will switch off immediately with a current fault.



According to [EN 60204-1](#) it is permissible to disconnect already tested components. Drive converters of the KEB Automation KG are delivered ex works voltage tested to 100% according to product standard.

### 1.4.3 Insulation measurement

An insulation measurement (in accordance with [EN 60204-1](#) chapter 18.3) with DC 500 V is permissible, if all power unit connections (grid-connected potential) and all control connections are bridged with PE. The insulation resistance of the respective device can be found in the technical data.

## 1.5 Start-up and operation

The drive converter must not be started until it is determined that the installation complies with the machine directive; Account is to be taken of [EN 60204-1](#).

### ⚠ WARNING

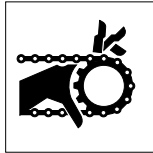

#### Software protection and programming!

##### Hazards caused by unintentional behavior of the drive!

- ▶ Check especially during initial start-up or replacement of the drive converter if parameterization is compatible to application.
- ▶ Securing a unit solely with software-supported functions is not sufficient. It is imperative to install external protective measures (e.g. limit switch) that are independent of the drive converter.
- ▶ Secure motors against automatic restart.

### ⚠ CAUTION



#### High temperatures at heat sink and coolant!

##### Burning of the skin!

- ▶ Cover hot surfaces safe-to-touch.
- ▶ If necessary, attach warning signs on the system.
- ▶ Before touching, check the surface and coolant lines.
- ▶ Before working let the unit cool down.

- During operation, all covers and doors shall be kept closed.
- Use only approved accessories for this device.
- Never touch terminals, busbars or cable ends.



If a drive converter with electrolytic capacitors in a DC link (see technical data) has not been in operation for more than one year, observe the following instructions.

[www.keb.de/fileadmin/media/Manuals/knowledge/04\\_techinfo/00\\_general/ti\\_format\\_capacitors\\_0400\\_0001\\_gbr.pdf](http://www.keb.de/fileadmin/media/Manuals/knowledge/04_techinfo/00_general/ti_format_capacitors_0400_0001_gbr.pdf)



### NOTICE

#### Continuous operation (S1) with load > 60% or from a rated motor power of 55 kW!

##### Premature ageing of the electrolytic capacitors!

- ▶ Mains choke with  $U_k = 4\%$  absolutely necessary.

### **Switching at the output**

Switching between motor and drive converter is prohibited for single drives during operation as this may trigger the protection gear of the device. Function ‚speed search‘ must be activated if switching can not be avoided. Speed search may only be triggered after closing the motor contactor (e.g. by switching the control release).

Connecting and disconnecting is permissible with multiple motor drives if at least 1 motor is running during the switch-over process. The drive converter must be dimensioned to the occurring starting currents.

The ‚speed search‘ function must be activated if the motor is still running during a restart of the drive converter (mains on) (e.g. due to large rotating masses).

### **Switching an the input**

For applications that require cyclic switching off and on of the drive converter, maintain an off-time of at least 5 min after the last switch on. If you require shorter cycle times please contact KEB Automation KG.

### **Short-circuit resistance**

The drive converters are conditional short-circuit proof. After resetting the internal protection devices, the function as directed is guaranteed.

Exceptions:

- If an earth-leakage fault or short-circuit often occurs at the output, this can lead to a defect in the unit.
- If a short-circuit occurs during regenerative operation (2nd or 4th quadrant, regeneration into the DC link), this can lead to a defect in the unit.

## **1.6 Maintenance**

The following maintenance work has to be carried out when required, but at least once per year by authorized and trained personnel. Check unit for loose screws and plugs and tighten if necessary.

- ▶ Check system for loose screws and plugs and tighten if necessary.
- ▶ Clean drive converter from dirt and dust deposits. Pay attention especially to cooling fins and protective grid of the fans.
- ▶ Examine and clean extracted air filter and cooling air filter of the control cabinet.
- ▶ Check the function of the fans of the drive converter. The fan must be replaced in case of audible vibrations or squeak.
- ▶ In the case of liquid-cooled drive converters a visual test of the cooling circuit for leaks and corrosion must be carried out. The cooling circuit must be completely empty if a unit shall be switched off for a longer period. The cooling circuit must be blown out additionally with compressed air at temperatures below 0°C.

## 1.7 Repair

In case of malfunction, unusual noises or smells inform a person in charge!

### DANGER



#### Unauthorized exchange, repair and modifications!

##### Unpredictable malfunctions!

- ▶ The function of the drive converter is dependent on its parameterization. Never replace without knowledge of the application.
- ▶ Modification or repair is permitted only by KEB Automation KG authorized personnel.
- ▶ Only use original manufacturer parts.
- ▶ Infringement will annul the liability for resulting consequences.

In case of failure, please contact the machine manufacturer. Only the machine manufacturer knows the parameterisation of the used drive converter and can provide an appropriate replacement or induce the maintenance.

## 1.8 Disposal

Electronic devices of the KEB Automation KG are exclusively professional devices for further industrial processing (so-called B2B devices).

Manufacturers of B2B devices are obliged to take back and recycle devices manufactured after 14.08.2018. These devices may not be disposed at the collection centres of public sector disposal organisations.



If no deviating agreement has been made between the customer and KEB or no deviating mandatory legal regulation exists, KEB products marked in this way can be returned. Company and keyword to the return point can be taken from the list below. Shipping costs are paid by the customer. Thereupon the devices will be professionally recycled and disposed.

The entry numbers are listed country-specific in the following table. The corresponding KEB return addresses can be found on our website.

Withdrawal by	WEEE-Reg.-No.	Keyword
<b>Austria</b>		
KEB Automation GmbH	ERA: 51976	Stichwort „Rücknahme WEEE“
<b>France</b>		
RÉCYLUM - Recycle point	ADEME: FR021806	Mots clés „KEB DEEE“
<b>Germany</b>		
KEB Automation KG	EAR: DE12653519	Stichwort „Rücknahme WEEE“
<b>Italy</b>		
COBAT	AEE: (IT) 19030000011216	Parola chiave „Ritiro RAEE“
<b>Spain</b>		
KEB Automation KG	RII-AEE 7427	Palabra clave „Retirada RAEE“
<b>Česko</b>		
KEB Automation KG	RETELA 09281/20 ECZ	Klíčové slovo: Zpětný odběr OEEZ

The packaging must be feed to paper and cardboard recycling.

## 2 Product Description

The drive controller series COMBIVERT S6 is optimized for the operation at synchronous and asynchronous motors. The integrated safety function STO has been developed for the use in safety-oriented applications.

The COMBIVERT meets the requirements of the Low-Voltage Directive. The harmonized standards of the series [EN 61800-5-1](#) for drive controllers were used.

The COMBIVERT is a product of limited availability in accordance with [EN 61800-3](#). This product may cause radio interference in residential areas. In this case the operator may need to take corresponding measures.

The machine directive, EMC directive, Low Voltage Directive and other guidelines and regulations must be observed depending on the version.

### 2.1 Specified application

The COMBIVERT serves exclusively for the control and regulation of three-phase motors. It is intended for the installation into electrical systems or machines.

Technical data and information for connection conditions shall be taken from the type plate and from the instruction manual and must be strictly observed.

The used semiconductors and components of the KEB Automation KG are developed and dimensioned for the use in industrial products.

#### **Restriction**

If the KEB COMBIVERT F5 is used in machines, which work under exceptional conditions or if essential functions, life-supporting measures or an extraordinary safety step must be fulfilled, the necessary reliability and security must be ensured by the machine builder.

#### 2.1.1 Residual risks

Despite intended use, the drive controller can reach unexpected operating conditions in case of error, with wrong parameterization, by faulty connection or unprofessional interventions and repairs. This can be:

- wrong direction of rotation
- motor speed too high
- motor is running into limitation
- motor can be under voltage even in standstill
- automatic start

### 2.2 Unintended use

The operation of other electric consumers is prohibited and can lead to the destruction of the unit. The operation of our products outside the indicated limit values of the technical data leads to the loss of any liability claims.

## 2.3 Product features

This instruction manual describes the power circuits of the following devices:

Device type:	Drive controller
Series:	COMBIVERT S6
Power range:	0.75...2.2 kW 400 V 3-phase 0.75...1.5 kW 230 V 1-phase
Housing:	2

The COMBIVERT S6 is characterized by the following features:

- For asynchronous, synchronous, IPM or synchronous reluctance motors
- With encoder or encoderless SCL and ASCL for accurate speed control
- Motor temperature monitoring PTC, KTY or PT1000
- Two-channel multi-encoder interface
- Integrated braking transistor
- Integrated brake control
- Integrated safety functionality
- Basic function STO in the compact version
- Additional high level safety in the application version
- Real-time Ethernet interfaces
- Following fieldbus systems are supported directly at S6: CAN, VARAN
- RS232/485 for diagnosis or display
- Book format for space-saving control cabinet construction
- Direct mains connection for 230V and 400V mains, alternatively also DC input 260...750 V
- Low leakage current mains filter (<5 mA) integrated, optional without filter
- High overload for best dynamics
- Supports existing machine concepts with 8 digital and 2 analog inputs, 2 digital outputs + 1 relay and 1 analog output 0...10 V





---

Due to the wide voltage range, the 3-phase 400V devices can also be operated at 230V applications, => „5.4 UL Marking“.

---

2.4 Type code

<b>xx</b>	<b>S6</b>	<b>x</b>	<b>x</b>	<b>x-x</b>	<b>x</b>	<b>x</b>	<b>x</b>
Reserved		0: Reserved					
Reserved		0: Reserved					
Type of control		<b>COMPACT</b> 1: Multi Encoder Interface, EtherCAT <sup>1)</sup> 2: Multi Encoder Interface, VARAN <b>APPLICATION</b> 1: Realtime Ethernet Module, Multi Encoder Interface <b>PRO</b> 1: Multi Encoder Interface / Ethernet-Fieldbus-Interface 4: no Encoder / Ethernet-Fieldbus-Interface / Safe relay 5: Multi Encoder Interface / Ethernet-Fieldbus-Interface / Safe relay					
Version power unit		1: AC 480V 3-phase with HF filter 2: AC 480V 3-phase without HF filter <sup>2)</sup> 3: AC 230V 1-phase with HF filter 4: AC 230V 1-phase without HF filter <sup>2)</sup>					
Housing		2, 4					
Safety module		1: Type 1 for Strg A (STO/SBC) or STO for Strg K 3: Type 3 for Strg A (STO/SBC/SLS etc.) 5: Type 5 STO / SLS / etc. FSOE					
Control type		A: APPLICATION K: COMPACT P: PRO					
Series		COMBIVERT S6					
Device size		07...14 <sup>3)</sup>					
<i>Table 1: Type code</i>							

<sup>1)</sup>  EtherCAT® is a registered trademark and patented technology licensed by the company Beckhoff Automation GmbH, Germany.

<sup>2)</sup> An external filter is required for these devices in order to comply with the limit values according to EN 61800-3.

<sup>3)</sup> Device size 14 is only available in the version without integrated HF filter.



The type code is not used as order code, but only for identification!



## 2.5 Nameplate

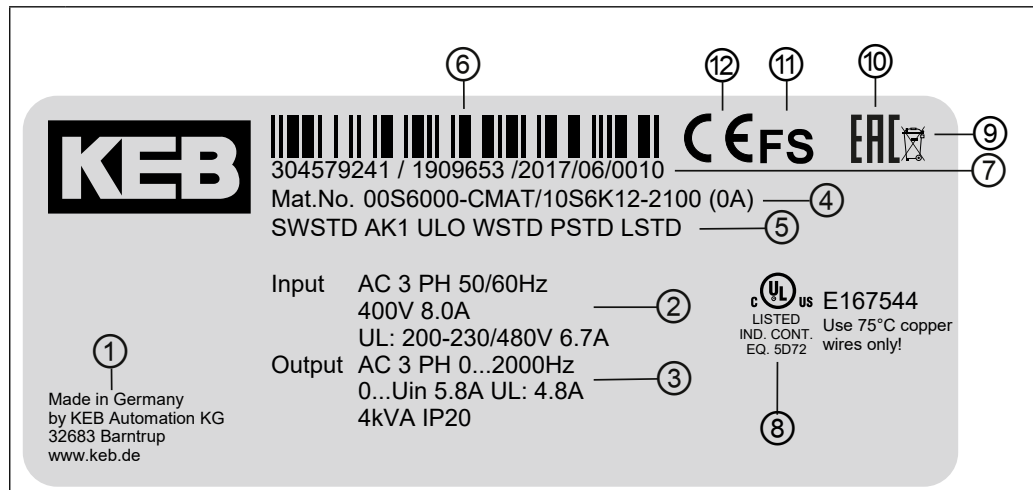

### Legend

1	Manufacturer identification
2	Technical data input
3	Technical data output
4	Material number, basic device => „2.4 Type code“, version number
5	Configurable options or customer material number/version => „2.5.1 Configurable options“
6	Barcode Interleaved 2/5 (serial number)
7	Serial number, order number; Year and week of manufacture; Factory
8	UL certification
9	Disposal information
10	EAC certification
11	FS certification
12	CE certification

Figure 1: Nameplate

**2.5.1 Configurable options**

<b>Features</b>	<b>Feature values</b>	<b>Description</b>
Software	SWxxx <sup>1)</sup>	Software version of the drive controller
Accessories	Axxx <sup>1)</sup>	Selected accessories
	NAK	No accessories
Clearing output frequency	LIM	Limitation to 599 Hz
	ULO	> 599 Hz available
Warranty	WSTD	Warranty - standard
	Wxxx <sup>1)</sup>	Warranty extension
Parameterization	PSTD	Parameterization - standard
	Pxxx <sup>1)</sup>	Parameterization - customer-specific
Nameplate logo	LSTD	Logo - standard
	Lxxx <sup>1)</sup>	Logo - customer-specific
<i>Table 2: Configurable options</i>		

<sup>1)</sup> "x" stands for a variable value.

## 3 Technical Data

Unless otherwise indicated, all electrical data in the following chapter refer to a 3-phase AC voltage supply.

### 3.1 Operating conditions

#### 3.1.1 Climatic environmental conditions

Storage	Standard	Class	Descriptions
Ambient temperature	<a href="#">EN 60721-3-1</a>	1K4	-25...55 °C
Relative humidity	<a href="#">EN 60721-3-1</a>	1K3	5...95 % (without condensation)
Storage height	–	–	Max. 3000 m above sea level
Transport	Standard	Class	Descriptions
Ambient temperature	<a href="#">EN 60721-3-2</a>	2K3	-25...70 °C
Relative humidity	<a href="#">EN 60721-3-2</a>	2K3	95 % at 40 °C (without condensation)
Operation	Standard	Class	Descriptions
Ambient temperature	<a href="#">EN 60721-3-3</a>	3K3	5...40 °C (extended to -10...45 °C)
Coolant inlet temperature	–	–	5...40 °C (-10...45 °C)
Relative humidity	<a href="#">EN 60721-3-3</a>	3K3	5...85 % (without condensation)
Version and degree of protection	<a href="#">EN 60529</a>	IP20	Protection against foreign material > ø12.5 mm No protection against water Non-conductive pollution, occasional condensation when PDS is out of service.
Site altitude	–	–	Max. 2000 m above sea level <ul style="list-style-type: none"> <li>• With site altitudes over 1000 m a derating of 1 % per 100 m must be taken into consideration.</li> <li>• With site altitudes over 2000 m, the control board to the mains has only basic isolation. Additional measures must be taken when wiring the control.</li> </ul>

Table 3: Climatic environmental conditions

**3.1.2 Mechanical environmental conditions**

<b>Storage</b>	<b>Standard</b>	<b>Class</b>	<b>Descriptions</b>
Vibration limits	<a href="#">EN 60721-3-1</a>	1M2	Vibration amplitude 1.5mm (2...9Hz) Acceleration amplitude 5m/s <sup>2</sup> (9...200Hz)
Shock limit values	<a href="#">EN 60721-3-1</a>	1M2	40 m/s <sup>2</sup> ; 22 ms
<b>Transport</b>	<b>Standard</b>	<b>Class</b>	<b>Descriptions</b>
Vibration limits	<a href="#">EN 60721-3-2</a>	2M1	Vibration amplitude 3.5mm (2...9Hz) Acceleration amplitude 10m/s <sup>2</sup> (9...200Hz) (Acceleration amplitude 15m/s <sup>2</sup> (200...500Hz)) <sup>1)</sup>
Shock limit values	<a href="#">EN 60721-3-2</a>	2M1	100 m/s <sup>2</sup> ; 11 ms
<b>Operation</b>	<b>Standard</b>	<b>Class</b>	<b>Descriptions</b>
Vibration limits	<a href="#">EN 60721-3-3</a>	3M4	Vibration amplitude 3.0mm (2...9Hz) Acceleration amplitude 10m/s <sup>2</sup> (9...200Hz)
	<a href="#">EN 61800-5-1</a>	–	Vibration amplitude 0.075mm (10...57Hz) Acceleration amplitude 10m/s <sup>2</sup> (57...150Hz)
Shock limit values	<a href="#">EN 60721-3-3</a>	3M4	100 m/s <sup>2</sup> ; 11 ms

*Table 4: Mechanical environmental conditions*

<sup>1)</sup> Not tested.

**3.1.3 Chemical / mechanical active substances**

<b>Storage</b>		<b>Standard</b>	<b>Class</b>	<b>Descriptions</b>
Contamination	Gases	<a href="#">EN 60721-3-11</a>	1C2	–
	Solids		1S2	–
<b>Transport</b>		<b>Standard</b>	<b>Class</b>	<b>Descriptions</b>
Contamination	Gases	<a href="#">EN 60721-3-22</a>	2C2	–
	Solids		2S2	–
<b>Operation</b>		<b>Standard</b>	<b>Class</b>	<b>Descriptions</b>
Contamination	Gases	<a href="#">EN 60721-3-3</a>	3C2	–
	Solids		3S2	–

*Table 5: Chemical / mechanical active substances*

### 3.1.4 Electrical operating conditions

#### 3.1.4.1 Device classification

Requirement	Standard	Class	Descriptions
Overvoltage category	EN 61800-5-1	III	–
	EN 60664-1		–
Pollution degree	EN 60664-1	2	Non-conductive pollution, occasional condensation when PDS is out of service.

Table 6: Device classification

#### 3.1.4.2 Electromagnetic compatibility

An external filter is required for devices without an internal filter in order to comply with the following limits.

EMC emitted interference	Standard	Class	Descriptions
Cable-conducted interferences	EN 61800-3	C2	–
Radiated interferences	EN 61800-3	C2	–
Immunity	Standard	Level	Descriptions
Static discharges	EN 61000-4-2	8 kV	AD (air discharge)
		4 kV	CD (contact discharge)
Burst - Ports for process measurement control lines and signal interfaces	EN 61000-4-4	2 kV	–
Burst - Power ports	EN 61000-4-4	4 kV	–
Surge - Power ports	EN 61000-4-5	1 kV	Phase-phase
		2 kV	Phase-ground
Immunity to conducted disturbances, induced by radio-frequency fields	EN 61000-4-6	10 V	0.15...80 MHz
Electromagnetic fields	EN 61000-4-3	10 V/m	80 MHz...1 GHz
		3 V/m	1.4...2 GHz
		1 V/m	2...2.7 GHz
Voltage fluctuations/ voltage dips	EN 61000-2-1 EN 61000-4-34	–	-15 %...+10 % 90 %
		–	≤ 2 %
Frequency changes	EN 61000-2-4	–	±10 %
Voltage deviations	EN 61000-2-4	–	±10 %
Voltage unbalance	EN 61000-2-4	–	≤ 3 %

Table 7: Electromagnetic compatibility

**3.2 Dimensions and weights**

**3.2.1 Built-in version**

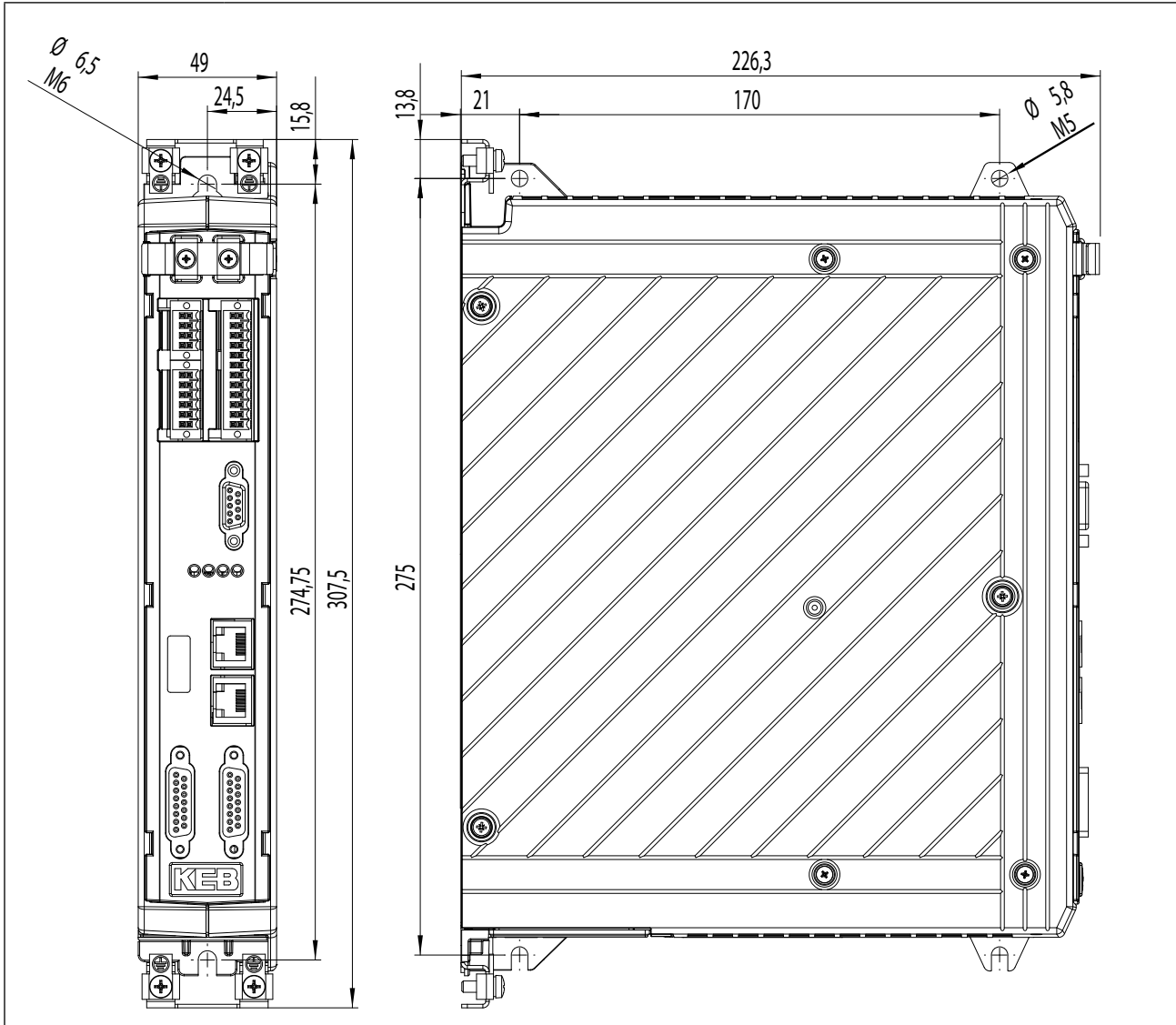

<b>Housing</b>	<b>2</b>
Weight	1.9 kg
Dimensions	All dimensions in mm

Figure 2: Dimensions built-in version housing 2

### 3.2.2 Control cabinet installation

Power dissipation for the control cabinet dimension => „3.6.5 Power dissipation 400 V devices“. A lower value can be used here depending on the operating mode/load.



#### Installation of the drive controller

For reliable operation, the drive controller must be installed without clearance on a smooth, closed, bare metal mounting plate.

Mounting distances	Dimension	Distance in mm	Distance in inch
	A	150	6
	B	100	4
	C	30	1.2
	D	0	0
	E	0	0
	F <sup>1)</sup>	50	2
	<sup>1)</sup> Distance to preceding elements in the cabinet door.		

Figure 3: Mounting distances

If construction-conditioned the control cabinet cannot be without indoor ventilation, appropriate filters must avoid suction of foreign objects.

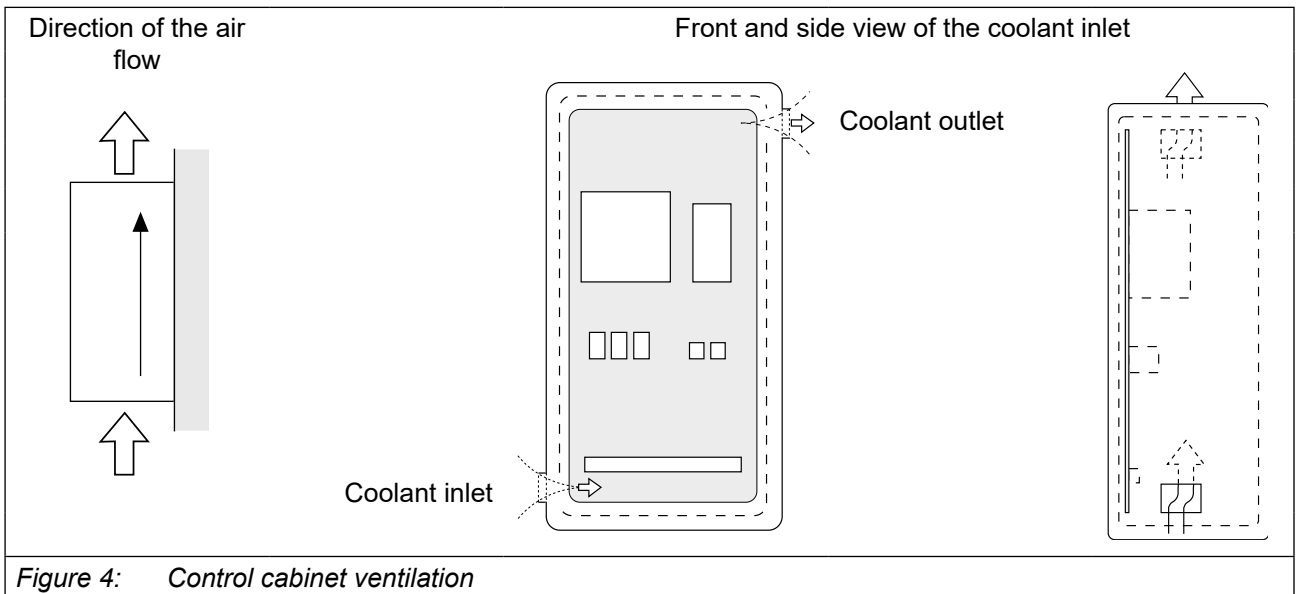

Figure 4: Control cabinet ventilation

### 3.3 Mounting instructions for control cabinet installation

For mounting the drive controllers, the following fastening materials with the corresponding quality were tested by KEB.

Required material	Tightening torque
Screw assembly ISO 7045 - M6 - 8.8	3.2 Nm 29 lb inch

*Table 8: Mounting instructions for control cabinet installation*

#### **NOTICE**

##### **Use of other fastening material**

- ▶ The alternatively selected fastening material must comply with the above-mentioned material characteristics (quality) and tightening torques !

The use of other fixing materials is beyond KEB's control and is therefore the sole responsibility of the customer.



### 3.3.1 Installation depth



For the various connections, it is recommended to keep the specified distance to upstream components.

The values given are approximate values. The actual installation depth must be checked individually by the user.

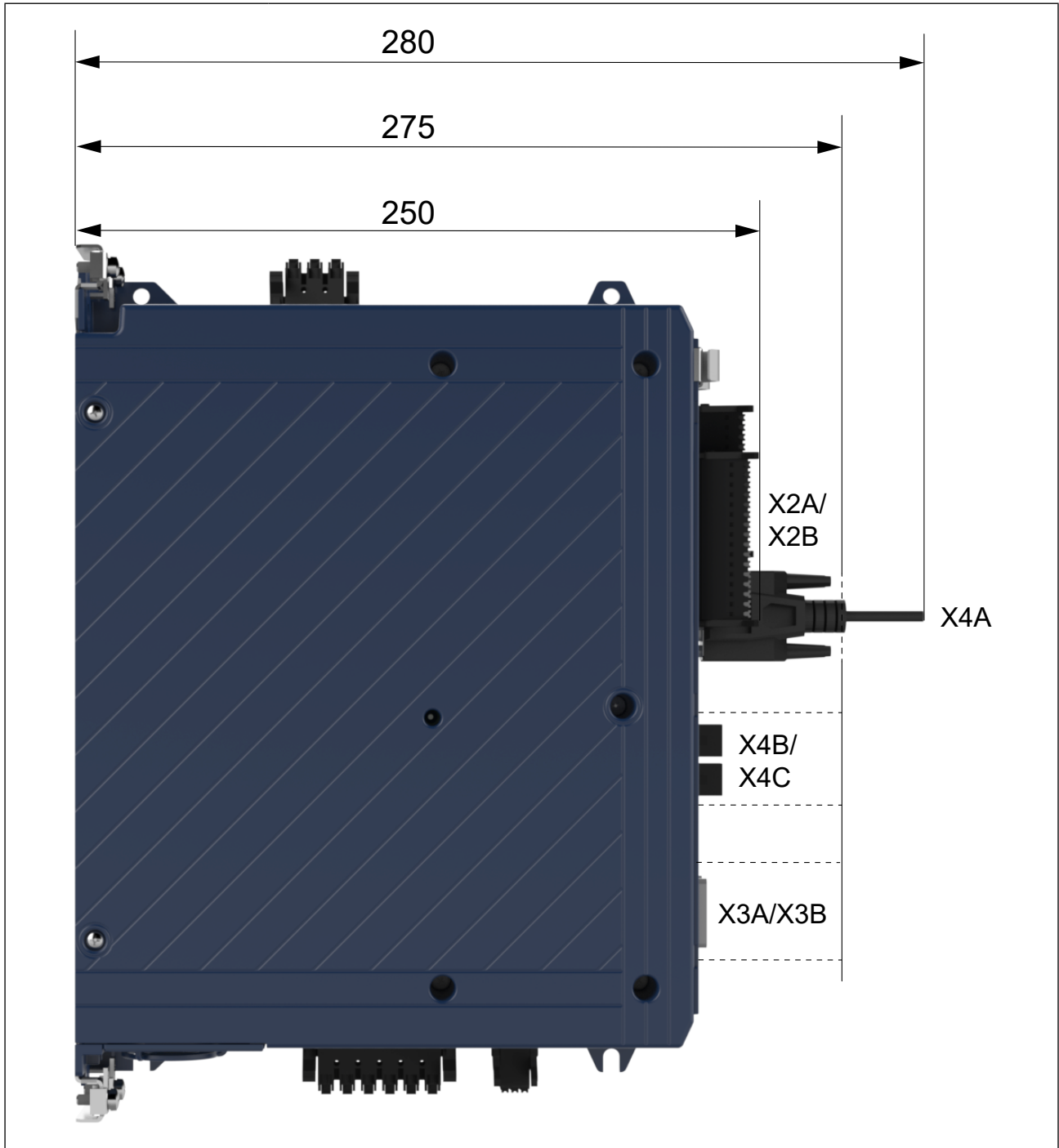

<b>Housing</b>	<b>2</b>
Dimensions	All dimensions in mm

Figure 5: Installation depth

### 3.4 Device data of the 400 V devices

#### 3.4.1 Overview of the 400V devices

The technical data are for 2/4-pole standard motors. With other pole numbers the drive controller must be dimensioned onto the motor rated current. Contact KEB for special or medium frequency motors.

Device size		07	09	10
Housing		2		
Rated apparent output power	$S_{out}$ / kVA	1.8	2.8	4.0
Max. rated motor power	$P_{mot}$ / kW	0.75	1.5	2.2
Rated output current	$I_N$ / A	2.6	4.1	5.8
Output voltage	$U_{out}$ / V	0... $U_{in}$ or 0... $U_{in\_dc}/\sqrt{2}$		
Output phases		3		
Output frequency	<sup>1)</sup> $f_{out}$ / Hz	0...599		
Rated output overload (60s)	<sup>2)</sup> $I_{60s}$ / %	200		
Rated output overload (3s)	<sup>2)</sup> $I_{3s}$ / %	250		
Overcurrent	<sup>2)</sup> $I_{OC}$ / %	300		
Rated switching frequency	$f_{SN}$ / kHz	8		
Rated input current	$I_{in}$ / A	3.6	6.0	8.0
Rated input voltage	$U_N$ / V	400		
Rated input voltage UL	$U_{N\_UL}$ / V	480		
Input voltage range	$U_{in}$ / V	184...550		
Input voltage range DC supply	$U_{in\_dc}$ / V	260...750		
Mains phases		3		
Mains frequency	$f_N$ / Hz	50/60		
Maximum current 0Hz/50Hz at $f_s = 4$ kHz	$I_{out\_max}$ / %	215/300	193/300	155/300
Maximum current 0Hz/50Hz at $f_s = 8$ kHz	$I_{out\_max}$ / %	162/300	132/300	103/275
Maximum current 0Hz/50Hz at $f_s = 16$ kHz	$I_{out\_max}$ / %	92/292	73/200	50/163
Insulation resistance @ $U_{dc} = 500$ V	$R_{iso}$ / M $\Omega$	> 15		
DC link capacity	$C$ / $\mu$ F	195	195	235

Table 9: Overview device data of the 400 V devices

<sup>1)</sup> The output frequency is to be limited in such a way that it does not exceed 1/10 of the switching frequency. Devices with higher max. output frequency are subject to export restrictions and are only available on request.

<sup>2)</sup> The values refer in % to the rated output current  $I_N$ .

#### 3.4.2 Rated operation

All rated values refer to a rated operation at  $U_N = 400$  V, rated switching frequency  $f_{SN}$  and an output frequency  $f_{out} = 50$  Hz.

### 3.4.3 Voltage and frequency specifications of the 400 V devices

Input voltage and frequencies		
Rated input voltage	$U_N / V$	400
Rated input voltage UL	$U_{N\_UL} / V$	230 / 480
Input voltage range	$U_{in} / V$	184...550
Mains phases		3
Mains frequency	$f_N / Hz$	50/60
Mains frequency tolerance	$\pm f_N / Hz$	$\pm 2$

Table 10: Input voltages and frequencies of the 400 V devices

Input voltage for DC operation		
Rated input voltage DC	$U_{N\_dc} / V$	565
Rated input voltage DC UL	$U_{N\_dc\_UL} / V$	680
Input voltage range DC supply	$U_{in\_dc} / V$	260...750 $\pm 0$

Table 11: Input voltages for DC operation of the 400 V devices

Output voltage and frequencies			
Output voltage at AC supply	<sup>1)</sup>	$U_{out} / V$	$3 \times 0 \dots U_{in}$
Output voltage at DC supply	<sup>1)</sup>	$U_{out\_dc} / V$	$3 \times 0 \dots U_{in\_dc} / \sqrt{2}$
Output frequency	<sup>2)</sup>	$f_{out} / Hz$	0...599

Table 12: Output voltages and frequencies of the 400 V devices

- <sup>1)</sup> The voltage to the motor is dependent on the actual input voltage and the control method (=> „3.4.3.1 Example for the calculation of the motor voltage“).
- <sup>2)</sup> The output frequency is to be limited in such a way that it does not exceed 1/10 of the switching frequency. Devices with higher max. output frequency are subject to export restrictions and are only available on request.

DC switching level		
DC switching level "Error! Underpotential"	$U_{UP\_dc} / V$	240
DC switching level braking resistor	<sup>1)</sup> $U_{B\_dc} / V$	780
DC switching level "Error! Overpotential"	$U_{OP\_dc} / V$	840

Table 13: DC switching level 400 V devices

- <sup>1)</sup> The DC switching level for the braking transistor is adjustable. The default value is the value specified in the table.

#### 3.4.3.1 Example for the calculation of the motor voltage

The motor voltage for dimensioning of the drive is depending on the used components. The mains voltage reduces according to the following table:

Components	Reduction / %	Example:
Mains choke $U_k$	4	Closed-loop drive controller with mains and motor choke at non-rigid supply system: 400 V mains voltage - 15% = 340 V motor voltage
Drive controller open-loop	4	
Drive controller closed-loop	8	
Motor choke $U_k$	1	
Non-rigid supply system	2	

Table 14: Example for the calculation of the motor voltage

3.4.4 Input and output currents / overload of the 400 V devices

Input currents 400 V devices				
Device size		07	09	10
Rated input current @ $U_N = 400\text{V}$	$I_{in} / \text{A}$	3.6	6.0	8.0
Rated input current UL @ $U_{N\_UL} = 480\text{V}$	$I_{in\_UL} / \text{A}$	2.9	4.7	6.7
Rated input current DC @ $U_{N\_dc} = 565\text{V}$	<sup>1)</sup> $I_{in\_dc} / \text{A}$	1.9	3.7	5.2
Rated input current DC UL @ $U_{N\_UL\_dc} = 680\text{V}$	<sup>1)</sup> $I_{in\_dc\_UL} / \text{A}$	3.6	5.8	8.0

Table 15: Input currents of the 400 V devices

<sup>1)</sup> The values resulting from rated operation with B6 rectifier circuit and mains choke 4%  $U_k$ .

Output currents 400 V devices				
Device size		07	09	10
Rated output current @ $U_N = 400\text{V}$	$I_N / \text{A}$	2.6	4.1	5.8
Rated output current UL @ $U_{N\_UL} = 480\text{V}$	$I_{N\_UL} / \text{A}$	2.1	3.4	4.8
Overload current (60s)	<sup>1)</sup> $I_{60s} / \%$	200		
Overload current (3s)	<sup>1)</sup> $I_{3s} / \%$	250		
Overcurrent	<sup>1)</sup> $I_{OC} / \%$	300		

Table 16: Output currents of the 400 V devices

<sup>1)</sup> The values refer in % to the rated output current  $I_N$ .

### 3.5 Device data of the 230 V devices

#### 3.5.1 Overview of the 230V devices

The technical data are for 2/4-pole standard motors. With other pole numbers the drive controller must be dimensioned onto the motor rated current. Contact KEB for special or medium frequency motors.

Device size		07	09
Housing		2	
Rated apparent output power	$S_{out}$ / kVA	1.6	2.8
Max. rated motor power	$P_{mot}$ / kW	0.75	1.5
Rated output current	$I_N$ / A	4	7
Output voltage	$U_{out}$ / V	$0 \dots U_{in\_dc} / \sqrt{2}$	
Output phases		3	
Output frequency	<sup>1)</sup> $f_{out}$ / Hz	0...599	
Rated output overload (60s)	<sup>2)</sup> $I_{60s}$ / %	150	
Rated output overload (3s)	<sup>2)</sup> $I_{3s}$ / %	200	
Overcurrent	<sup>2)</sup> $I_{oc}$ / %	240	
Rated switching frequency	$f_{SN}$ / kHz	8	
Rated input current	$I_{in}$ / A	8	14
Rated input voltage	$U_N$ / V	230	
Input voltage range	$U_{in}$ / V	184...265	
Input voltage range DC supply	$U_{in\_dc}$ / V	260...375	
Mains phases		1	
Mains frequency	$f_N$ / Hz	50/60	
Maximum current 0 Hz/50 Hz at $f_s = 4$ kHz	$I_{out\_max}$ / %	175/240	157/240
Maximum current 0 Hz/50 Hz at $f_s = 8$ kHz	$I_{out\_max}$ / %	150/240	114/240
Maximum current 0 Hz/50 Hz at $f_s = 16$ kHz	$I_{out\_max}$ / %	100/240	85/240
Insulation resistance @ $U_{dc} = 500$ V	$R_{iso}$ / M $\Omega$	> 5	
DC link capacity	$C$ / $\mu$ F	1170	1410

Table 17: Overview device data of the 230 V devices

<sup>1)</sup> The output frequency is to be limited in such a way that it does not exceed 1/10 of the switching frequency. Devices with higher max. output frequency are subject to export restrictions and are only available on request.

<sup>2)</sup> The values refer in % to the rated output current  $I_N$ .

#### 3.5.2 Rated operation

All rated values refer to a rated operation at  $U_N = 230$  V, rated switching frequency  $f_{SN}$  and an output frequency  $f_{out} = 50$  Hz.

3.5.3 Voltage and frequency specifications of the 230 V devices

Input voltage and frequencies		
Rated input voltage	$U_N / V$	120...230
Rated input voltage UL	$U_{N\_UL} / V$	120...230
Input voltage range	$U_{in} / V$	184...265
Mains phases		1
Mains frequency	$f_N / \text{Hz}$	50/60
Mains frequency tolerance	$\pm f_N / \text{Hz}$	$\pm 2$

Table 18: Input voltages and frequencies of the 230 V devices

Input voltage for DC operation		
Rated input voltage DC	$U_{N\_dc} / V$	325
Input voltage range DC supply	$U_{in\_dc} / V$	260...375

Table 19: Input voltages for DC operation of the 230 V devices

Output voltage and frequencies		
Output voltage at AC supply	<sup>1)</sup> $U_{out} / V$	$3 \times 0 \dots U_{in}$
Output voltage at DC supply	<sup>1)</sup> $U_{out\_dc} / V$	$3 \times 0 \dots U_{in\_dc} / \sqrt{2}$
Output frequency	<sup>2)</sup> $f_{out} / \text{Hz}$	0...599

Table 20: Output voltages and frequencies of the 230 V devices

<sup>1)</sup> The voltage to the motor is dependent on the actual input voltage and the control method (=> „3.4.3.1 Example for the calculation of the motor voltage“).

<sup>2)</sup> The output frequency is to be limited in such a way that it does not exceed 1/10 of the switching frequency. Devices with higher max. output frequency are subject to export restrictions and are only available on request.

DC switching level		
DC switch-off level "Error! Underpotential"	$U_{UP\_dc} / V$	260
DC switching level braking resistor	<sup>1)</sup> $U_{B\_dc} / V$	380
DC switch-off level "Error! Overpotential"	$U_{OP\_dc} / V$	420

Table 21: DC switching level of the 230 V devices

<sup>1)</sup> The DC switching level for the braking transistor is adjustable. The default value is the value specified in the table.

3.5.4 Input and output currents / overload of the 230 V devices

Input currents 230 V devices			
Device size		07	09
Rated input current @ $U_N = 230\text{ V}$	$I_{in} / \text{ A}$	8	14
Rated input current UL @ $U_{N\_UL} = 230\text{ V}$	$I_{in\_UL} / \text{ A}$	8	14
Rated input current DC @ $U_{N\_dc} = 325\text{ V}$	<sup>1)</sup> $I_{in\_dc} / \text{ A}$	3.3	6.2
Rated input current DC UL @ $U_{N\_UL\_dc} = 325\text{ V}$	<sup>1)</sup> $I_{in\_dc\_UL} / \text{ A}$	3.3	6.2

Table 22: Input currents of the 230 V devices

<sup>1)</sup> The values resulting from rated operation with B6 rectifier circuit and mains choke 4%  $U_k$ .

Output currents 230 V devices			
Device size		07	09
Rated output current @ $U_N = 230\text{ V}$	$I_N / \text{ A}$	4	7
Rated output current UL @ $U_{N\_UL} = 230\text{ V}$	$I_{N\_UL} / \text{ A}$	4	7
Rated output overload (60s)	<sup>1)</sup> $I_{60s} / \%$	150	
Rated output overload (3s)	<sup>1)</sup> $I_{3s} / \%$	200	
Overcurrent	<sup>1)</sup> $I_{oc} / \%$	240	

Table 23: Output currents of the 230 V devices

<sup>1)</sup> The values refer in % to the rated output current  $I_N$ .

## 3.6 General data

### 3.6.1 Overload characteristic (OL)

All COMBIVERT S6 can be operated time-limited at rated switching frequency even in overload. Further information can be found in the diagrams „Figure 6: Switch-off time  $t$  depending on the overload  $I/I_N$  (OL) 400 V devices“ and „Figure 7: Switch-off time  $t$  depending on the overload  $I/I_N$  (OL) 230 V devices“.

#### Restrictions:

- The thermal design of the heat sink is based on the rated current and the maximum permissible ambient temperature. At high ambient temperatures and/or high heat sink temperatures (for example, by preceding utilization nearby 100%), the drive controller can change to overtemperature error before triggering the protective function OL.
- At low output frequencies or switching frequencies higher than the rated switching frequency, the maximum current (10Hz/16Hz) can be exceeded before and the error OL2 can be triggered (see also chapter "Maximum current (OL2)").

On exceeding a load of 105% the overload integrator starts. When falling below the integrator counts backwards. If the integrator achieves the overload characteristic, "Error! Overload" is triggered.

After a cooling period the message "no ERROR overload" is displayed. The error can be reset now. The drive controller must remain switched on during the cooling down phase.



3.6.1.1 Switch-off time depending on the overload at 400V devices

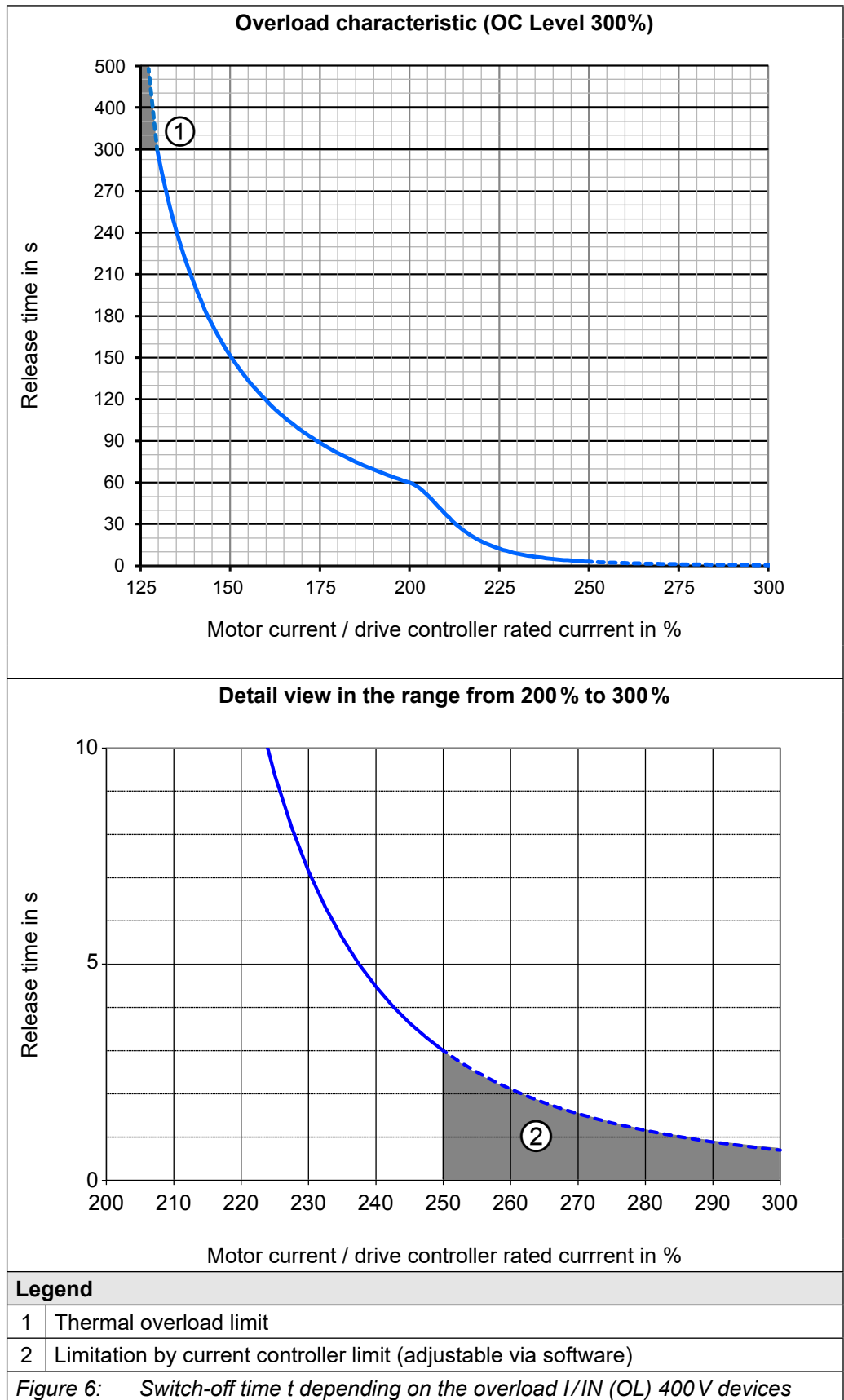

3.6.1.2 Switch-off time depending on the overload at 230 V devices

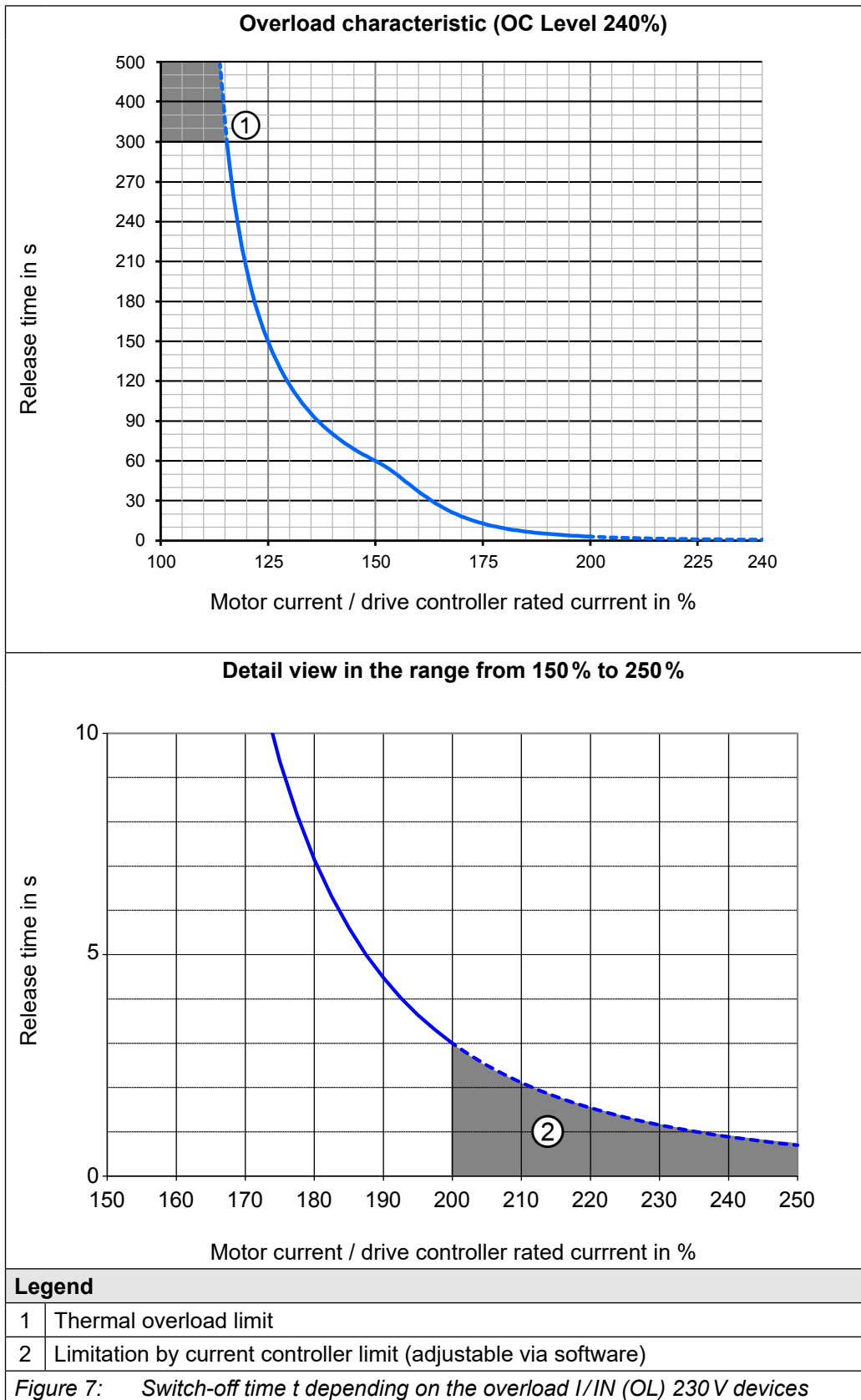

### 3.6.1.3 Maximum current (OL2)

It can be adjusted in the drive controller parameters if error (OL2) shall be triggered when exceeding the maximum currents, or if the switching frequency is automatically reduced (derating).

The following tables indicate the permissible maximum current for 6 output frequency values. In between there is a linear interpolation. Device size 07 is represented exemplary.

#### Overload characteristic in the lower speed range (OL2)

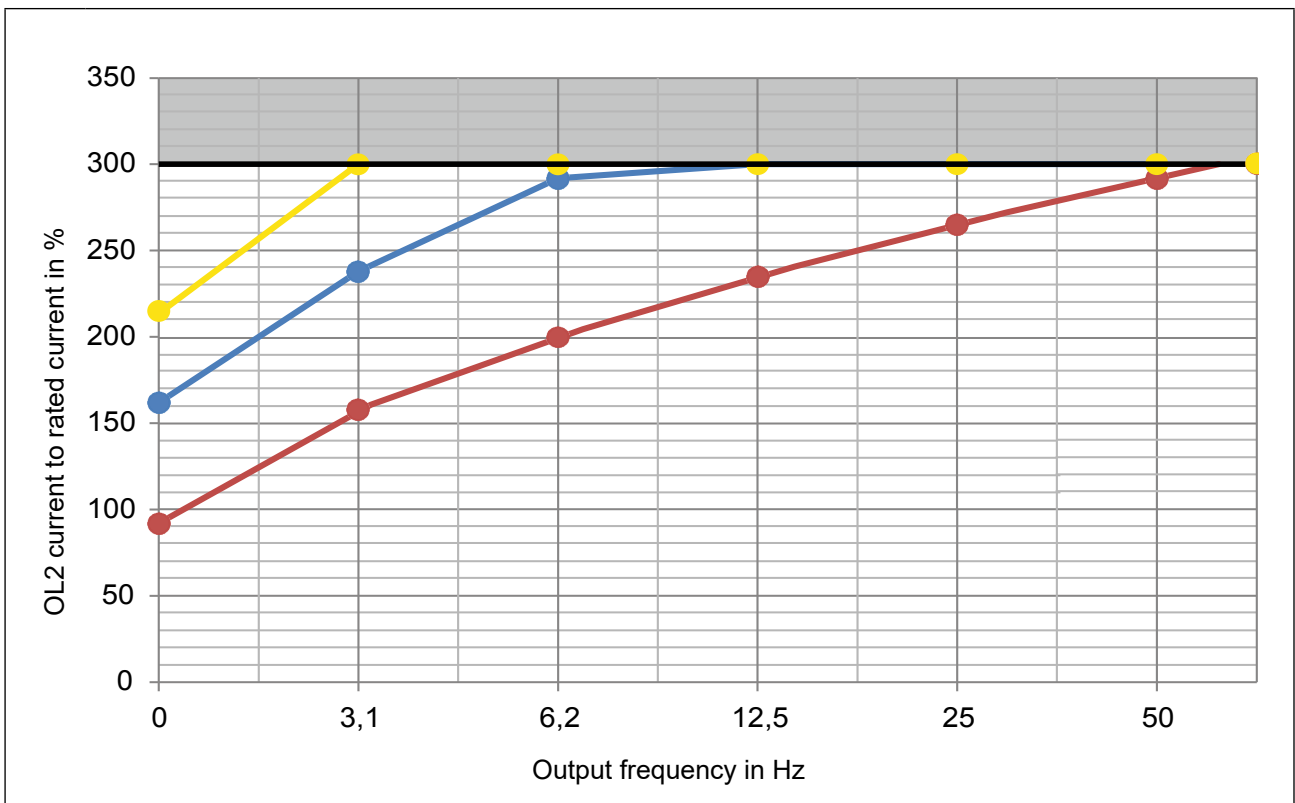

The characteristic curves represent the real maximum current values using the example of device size 07 (400 V).

**Legend**

	Overcurrent $I_{oc}$
	Switching frequency 4 kHz
	Switching frequency 8 kHz
	Switching frequency 16 kHz
	Not available for modulation. The error OC is triggered at 300 % overload.

Figure 8: Overload characteristic in the lower speed range (OL2)



The frequency-dependent maximum current  $I_{out\_max}$  refers in % to the rated output current  $I_N$ .

From the last specified output frequency value, the current remains constant.



The values for the respective device size are listed in the following tables.

**Frequency-dependent maximum current 400 V devices**

Device size		07					
Rated switching frequency		8 kHz					
Output frequency	$f_{out}$ / Hz	0	3.1	6.2	12.5	25	50
Frequency-dependent maximum current @ $f_s$ Basic Time Period = 62.5 $\mu$ s (Parameter is22=0)	$i_{out\_max}$ / %						
		4 kHz	215	300	300	300	300
		8 kHz	162	238	292	300	300
Frequency-dependent maximum current @ $f_s$ Basic Time Period = 71.4 $\mu$ s (Parameter is22=1)	$i_{out\_max}$ / %						
		7 kHz	175	254	300	300	300
		14 kHz	104	175	215	252	287
Frequency-dependent maximum current @ $f_s$ Basic Time Period = 83.3 $\mu$ s (Parameter is22=2)	$i_{out\_max}$ / %						
		6 kHz	188	269	300	300	300
		12 kHz	115	192	231	269	308
Frequency-dependent maximum current @ $f_s$ Basic Time Period = 100 $\mu$ s (Parameter is22=3)	$i_{out\_max}$ / %						
		5 kHz	202	285	300	300	300
		10 kHz	138	215	262	300	300

Table 24: Frequency-dependent maximum current for device size 07 400 V devices

Device size		09					
Rated switching frequency		8 kHz					
Output frequency	$f_{out}$ / Hz	0	3.1	6.2	12.5	25	50
Frequency-dependent maximum current @ $f_s$ Basic Time Period = 62.5 $\mu$ s (Parameter is22=0)	$i_{out\_max}$ / %						
		4 kHz	193	266	300	300	300
		8 kHz	132	198	234	256	283
Frequency-dependent maximum current @ $f_s$ Basic Time Period = 71.4 $\mu$ s (Parameter is22=1)	$i_{out\_max}$ / %						
		7 kHz	147	215	253	276	300
		14 kHz	85	138	159	180	201
Frequency-dependent maximum current @ $f_s$ Basic Time Period = 83.3 $\mu$ s (Parameter is22=2)	$i_{out\_max}$ / %						
		6 kHz	162	232	272	296	300
		12 kHz	98	154	171	195	220
Frequency-dependent maximum current @ $f_s$ Basic Time Period = 100 $\mu$ s (Parameter is22=3)	$i_{out\_max}$ / %						
		5 kHz	177	249	291	300	300
		10 kHz	115	176	202	226	251

Table 25: Frequency-dependent maximum current for device size 09 400 V devices

Device size		10					
Rated switching frequency		8 kHz					
Output frequency	$f_{out}$ / Hz	0	3.1	6.2	12.5	25	50
Frequency-dependent maximum current @ $f_s$ Basic Time Period = 62.5 $\mu$ s (Parameter is22=0)	$i_{out\_max}$ / %						
		4 kHz	155	250	284	300	300
		8 kHz	103	172	207	233	255
Frequency-dependent maximum current @ $f_s$ Basic Time Period = 71.4 $\mu$ s (Parameter is22=1)	$i_{out\_max}$ / %						
		7 kHz	116	192	226	254	278
		14 kHz	64	116	138	155	177
Frequency-dependent maximum current @ $f_s$ Basic Time Period = 83.3 $\mu$ s (Parameter is22=2)	$i_{out\_max}$ / %						
		6 kHz	129	211	246	276	300
		12 kHz	78	129	155	172	198
Frequency-dependent maximum current @ $f_s$ Basic Time Period = 100 $\mu$ s (Parameter is22=3)	$i_{out\_max}$ / %						
		5 kHz	142	231	265	297	300
		10 kHz	91	151	181	203	227

Table 26: Frequency-dependent maximum current for device size 10 400 V devices

**Frequency-dependent maximum current 230 V devices**

Device size		07					
Rated switching frequency		8 kHz					
Output frequency	$f_{out}$ / Hz	0	3.1	6.2	12.5	25	50
Frequency-dependent maximum current @ $f_s$ Basic Time Period = 62.5 $\mu$ s (Parameter is22=0)	4 kHz	175	240	240	240	240	240
	$i_{out\_max}$ / %	150	200	240	240	240	240
	8 kHz	150	200	240	240	240	240
Frequency-dependent maximum current @ $f_s$ Basic Time Period = 71.4 $\mu$ s (Parameter is22=1)	16 kHz	100	150	200	240	240	240
	$i_{out\_max}$ / %	156	213	240	240	240	240
	7 kHz	156	213	240	240	240	240
Frequency-dependent maximum current @ $f_s$ Basic Time Period = 83.3 $\mu$ s (Parameter is22=2)	14 kHz	113	163	213	240	240	240
	$i_{out\_max}$ / %	163	225	240	240	240	240
	6 kHz	163	225	240	240	240	240
Frequency-dependent maximum current @ $f_s$ Basic Time Period = 100 $\mu$ s (Parameter is22=3)	12 kHz	125	175	225	240	240	240
	$i_{out\_max}$ / %	169	238	240	240	240	240
	5 kHz	169	238	240	240	240	240
		10 kHz	138	188	238	240	240

Table 27: Frequency-dependent maximum current for device size 07 230 V devices

Device size		09					
Rated switching frequency		8 kHz					
Output frequency	$f_{out}$ / Hz	0	3.1	6.2	12.5	25	50
Frequency-dependent maximum current @ $f_s$ Basic Time Period = 62.5 $\mu$ s (Parameter is22=0)	4 kHz	157	214	240	240	240	240
	$i_{out\_max}$ / %	114	171	229	240	240	240
	8 kHz	114	171	229	240	240	240
Frequency-dependent maximum current @ $f_s$ Basic Time Period = 71.4 $\mu$ s (Parameter is22=1)	16 kHz	86	143	200	229	240	240
	$i_{out\_max}$ / %	125	182	234	240	240	240
	7 kHz	125	182	234	240	240	240
Frequency-dependent maximum current @ $f_s$ Basic Time Period = 83.3 $\mu$ s (Parameter is22=2)	14 kHz	93	150	207	232	240	240
	$i_{out\_max}$ / %	136	193	239	240	240	240
	6 kHz	136	193	239	240	240	240
Frequency-dependent maximum current @ $f_s$ Basic Time Period = 100 $\mu$ s (Parameter is22=3)	12 kHz	100	157	214	236	240	240
	$i_{out\_max}$ / %	146	204	240	240	240	240
	5 kHz	146	204	240	240	240	240
		10 kHz	107	164	221	240	240

Table 28: Frequency-dependent maximum current for device size 09 230 V devices

**3.6.2 Switching frequency and temperature**

The drive controller cooling is designed by way that the heat sink overtemperature threshold is not exceeded at rated conditions. A switching frequency higher than the rated switching frequency also produces higher losses and thus a higher heat sink heating.

If the heat sink temperature reaches a critical threshold ( $T_{dr}$ ) the switching frequency can be reduced automatically step by step, in order to prevent that the drive controller switches off due to overheating of the heat sink. If the heat sink temperature falls below  $T_{ur}$ , the switching frequency is increased to the setpoint again. At temperature  $T_{em}$  the switching frequency is immediately reduced to rated switching frequency. "Derating" must be activated, for this function to work.

Voltage class	400 V			230 V	
	07	09	10	07	09
Device size					
Mains phases	3			1	
Rated switching frequency <sup>1)</sup> $f_{SN}$ / kHz	8			8	
Max. switching frequency <sup>1)</sup> $f_{S\_max}$ / kHz	16			16	
Max. heat sink temperature $T_{HS}$ / °C	90			80	
Temperature for derating the switching frequency <sup>2)</sup> $T_{dr}$ / °C	80			70	
Temperature for uprating the switching frequency <sup>2)</sup> $T_{ur}$ / °C	70			60	
Temperature for switching to rated switching frequency <sup>2)</sup> $T_{em}$ / °C	85			75	

Table 29: Switching frequency and temperature

- <sup>1)</sup> The output frequency is to be limited in such a way that it does not exceed 1/10 of the switching frequency.
- <sup>2)</sup> On reaching the temperature  $T_{dr}$  the switching frequency is step down. The switching frequency is increased again on cooling down to temperature  $T_{ur}$ .  
If derating is not requested in individual cases, the function can be deactivated via software.

### 3.6.3 Protection of the drive controller

#### 3.6.3.1 400V units, 3-phase

At 400V operation, 3-phase			
Device size	Fuse in A		Alternatively Motor protection switch
	$U_N = 400\text{ V}$ gG (IEC)	$U_N = 480\text{ V}$ Class „CC“ or „J“ (UL)	Eaton PKZM0 10-E (UL)
	SCCR 30 kA	SCCR 30 kA	SCCR 30 kA
07	6	6	480Y/277V, 7.5HP
09	10	10	
10	10	10	
At 230V operation, 3-phase			
Device size	Fuse in A		Alternatively Motor protection switch
	$U_N = 230\text{ V}$ gG (IEC)	$U_N = 200\text{-}230\text{ V}$ class „CC“ (UL)	Eaton PKZM0 10-E (UL)
	SCCR 30 kA	SCCR 30 kA	SCCR 30 kA
07	6	6	200-230V, 3HP
09	10	10	
10	10	10	

Table 30: Fusing of the drive controllers 400 V devices, 3-phase

#### 3.6.3.2 230V devices, 1-phase

Device size	Fuse in A		Alternatively Motor protection switch
	$U_N = 230\text{ V}$ gG (IEC)	$U_N = 120\text{-}230\text{ V}$ class „CC“ <sup>1)</sup>	Eaton PKZM0 20-E <sup>2)</sup>
	SCCR 30 kA	SCCR 30 kA	SCCR 5 kA
07	15	15	115V/1ph, 1.5hp
09	20	20	230V/1ph, 3hp

Table 31: Fusing of the drive controllers 230 V devices, 1-phase

<sup>1)</sup> For mains with an unaffected symmetrical short-circuit current of max. 5kA eff. additional fuses of the class J are permissible.

<sup>2)</sup> Class "J" fuses are also possible up to 5 kA SCCR.



#### Short-circuit capacity

After requests from *EN 60439-1* and *EN 61800-5-1* the following is valid for the connection to a network: The devices are suitable for use in a circuit capable of delivering not more than 30 kA eff. unaffected symmetrical short-circuit current.

3.6.4 DC link / braking transistor function

3.6.4.1 DC link / braking transistor function of the 400V devices

Device size		07	09	10
DC link rated voltage @ $U_N = 400V$	$U_{N\_dc} / V$	565		
DC link rated voltage @ $U_N = 480V$	$U_{N\_dc\_UL} / V$	672		
DC link voltage working voltage range	$U_{in\_dc} / V$	260...750 ±0		
DC switch-off level "Error! Underpotential"	$U_{UP} / V$	240		
DC switch-off level "Error! Overpotential"	$U_{OP} / V$	840		
Rated current @ $U_{in\_dc} = 565V$	$I_{in\_dc} / A$	1.9	3.7	5.2
Rated current UL @ $U_{in\_dc} = 680V$	$I_{in\_dc\_UL} / A$	1.6	3.1	4.3
Rated current @ $U_{out\_dc} = 565V$	$I_{out\_max\_dc} / A$	1.9	3.7	5.2
Rated current UL @ $U_{out\_dc} = 680V$	$I_{out\_max\_dc\_UL} / A$	1.6	3.1	4.3
DC switching level braking transistor	<sup>1)</sup> $U_B / V$	780		
Max. braking current	$I_{B\_max} / A$	5.5	8	11
Min. braking resistor value	$R_{B\_min} / \Omega$	160	110	82
Protective function for braking transistor	<sup>2)</sup>	—		

Table 32: DC link / braking transistor function of the 400 V devices

- <sup>1)</sup> The DC switching level for the braking transistor is adjustable. The default value is the value specified in the table.
- <sup>2)</sup> No protective function, => „4.2.7.2 Use of intrinsically safe braking resistors“.

3.6.4.2 DC link / braking transistor function of the 230V devices

Device size		07	09
DC link rated voltage @ $U_N = 230V$	$U_{N\_dc} / V$	325	
DC link rated voltage @ $U_{N\_UL} = 230V$	$U_{N\_dc\_UL} / V$	325	
DC link voltage working voltage range	$U_{in\_dc} / V$	260...375 ±0	
DC switch-off level "Error! Underpotential"	$U_{UP} / V$	260	
DC switch-off level "Error! Overpotential"	$U_{OP} / V$	420	
Rated current @ $U_{in\_dc} = 325V$	$I_{in\_dc} / A$	3.3	6.2
Rated current UL @ $U_{in\_dc} = 325V$	$I_{in\_dc\_UL} / A$	3.3	6.2
Rated current @ $U_{out\_dc} = 325V$	$I_{out\_max\_dc} / A$	3.3	6.2
Rated current UL @ $U_{out\_dc} = 325V$	$I_{out\_dc\_max\_UL} / A$	3.3	6.2
DC switching level braking transistor	<sup>1)</sup> $U_B / V$	380	
Max. braking current	$I_{B\_max} / A$	7.5	12.7
Min. brake resistance value	$R_{B\_min} / \Omega$	56	33
Protective function for braking transistor	<sup>2)</sup>	—	

Table 33: DC link / braking transistor function of the 230 V devices

- <sup>1)</sup> The DC switching level for the braking transistor is adjustable. The default value is the value specified in the table.
- <sup>2)</sup> No protective function, => „4.2.7.2 Use of intrinsically safe braking resistors“.



**NOTICE**

**Destruction of the drive controller!**

**Falling below the minimum braking resistor value**

► The minimum brake resistance value must not fall below!

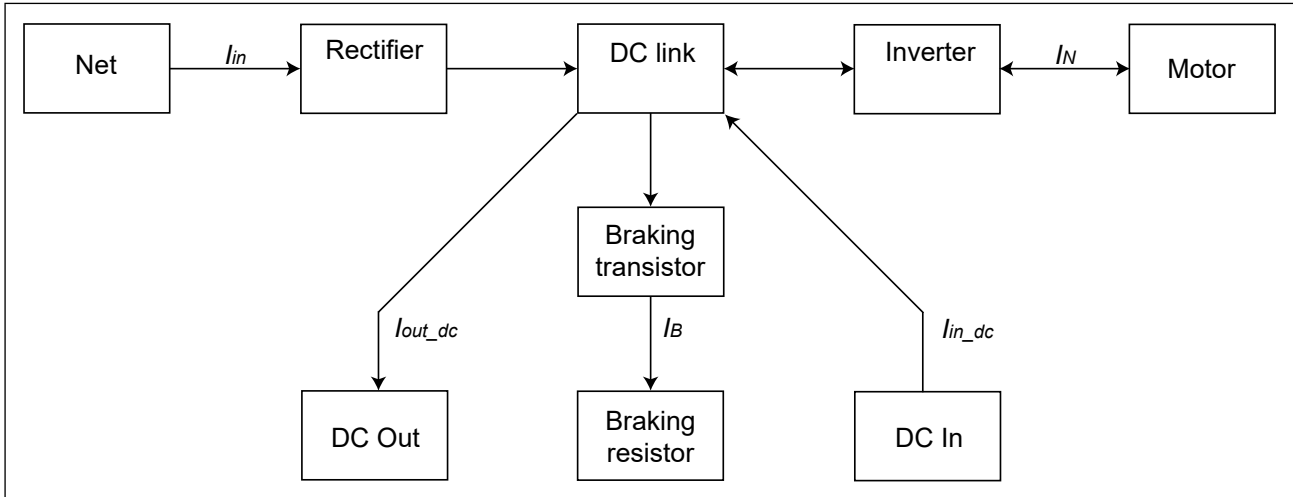

Figure 9: Block diagram of the energy flow



**Activation of the braking transistor function**

The function must be activated with parameter "is30 braking transistor function" in order to use the braking transistor.

Further information can be found in the download area of [www.keb.de](http://www.keb.de) under the search term „S6 Programming manual“.

**3.6.5 Power dissipation 400V devices**

Device size		07	09	10
Power dissipation at rated operation	<sup>1)</sup> $P_D / W$	50	57	80
Power dissipation at DC supply	<sup>1)</sup> $P_{D\_dc} / W$	31	46	63

Table 34: Power dissipation 400V devices

<sup>1)</sup> Rated operation corresponds to  $U_N=400V$ ;  $f_{SN}$ ;  $f_{out}=50Hz$  (typically value).

**3.6.6 Power dissipation 230V devices**

Device size		07	09
Power dissipation at rated operation	<sup>1)</sup> $P_D / W$	60	95
Power dissipation at DC supply	<sup>1)</sup> $P_{D\_dc} / W$	70	50

Table 35: Power dissipation 230V devices

<sup>1)</sup> Rated operation corresponds to  $U_N=400V$ ;  $f_{SN}$ ;  $f_{out}=50Hz$  (typically value).

3.6.7 Fan

Device size		07	09	10
Heat sink fan	Number	1		
	Speed-variable	—		

**NOTICE**

**Destruction of the fan!**

► Take care that no foreign substances drop into the fan !

3.6.7.1 Switching behaviour of the fan

The fan has different switch-on and switch-off points. The switching point for the switch-on temperature ① of the fan is adjustable. The switching point for the switch-off temperature ② cannot be changed and is always 5°C below the switch-on temperature.

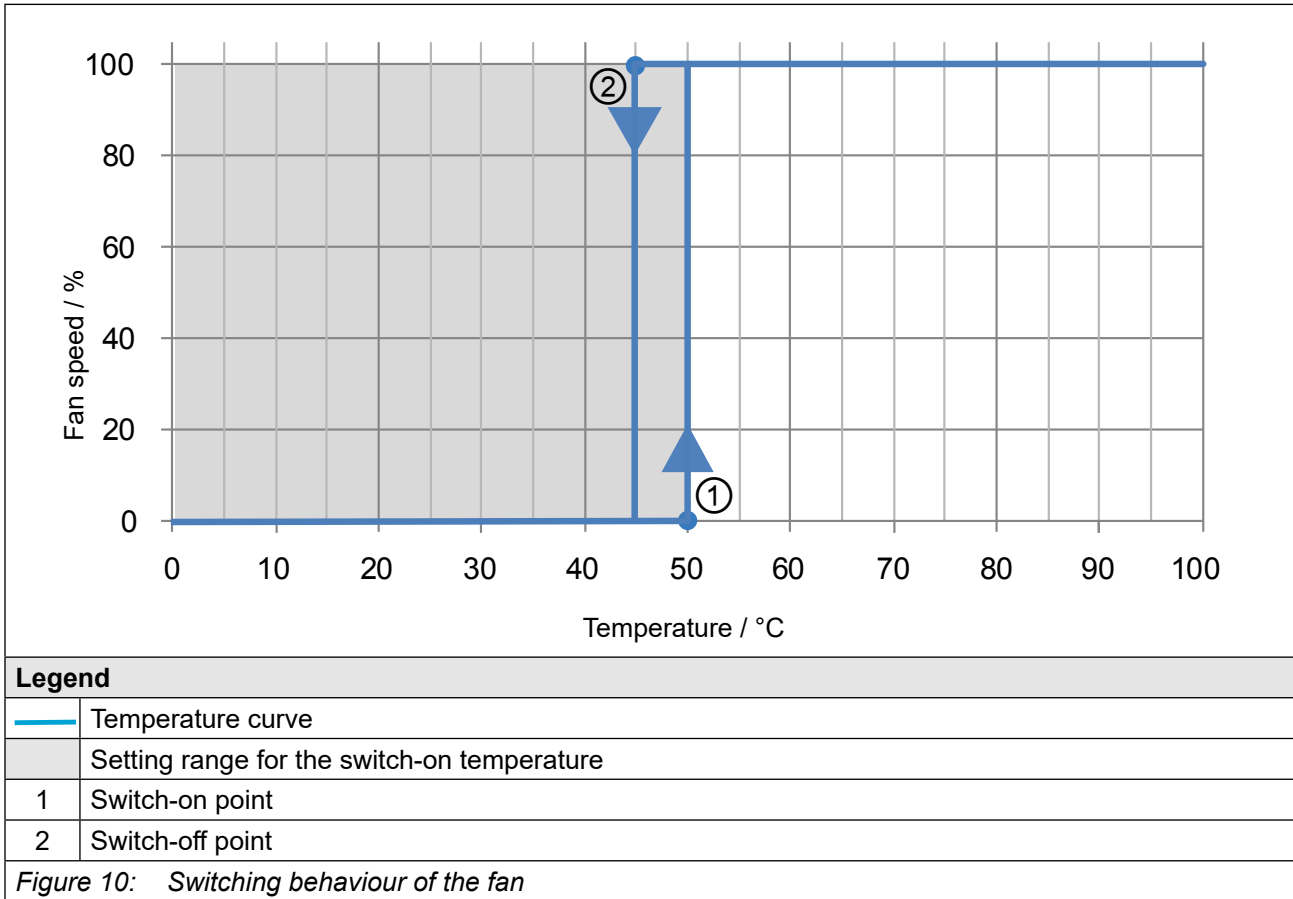

3.6.7.2 Switching points of the fan

The switching point for the switch-on temperature is adjustable between 0.1°C and 50°C. The default value is 50°C.

# 4 Installation and Connection

## 4.1 Overview of the COMBIVERT S6

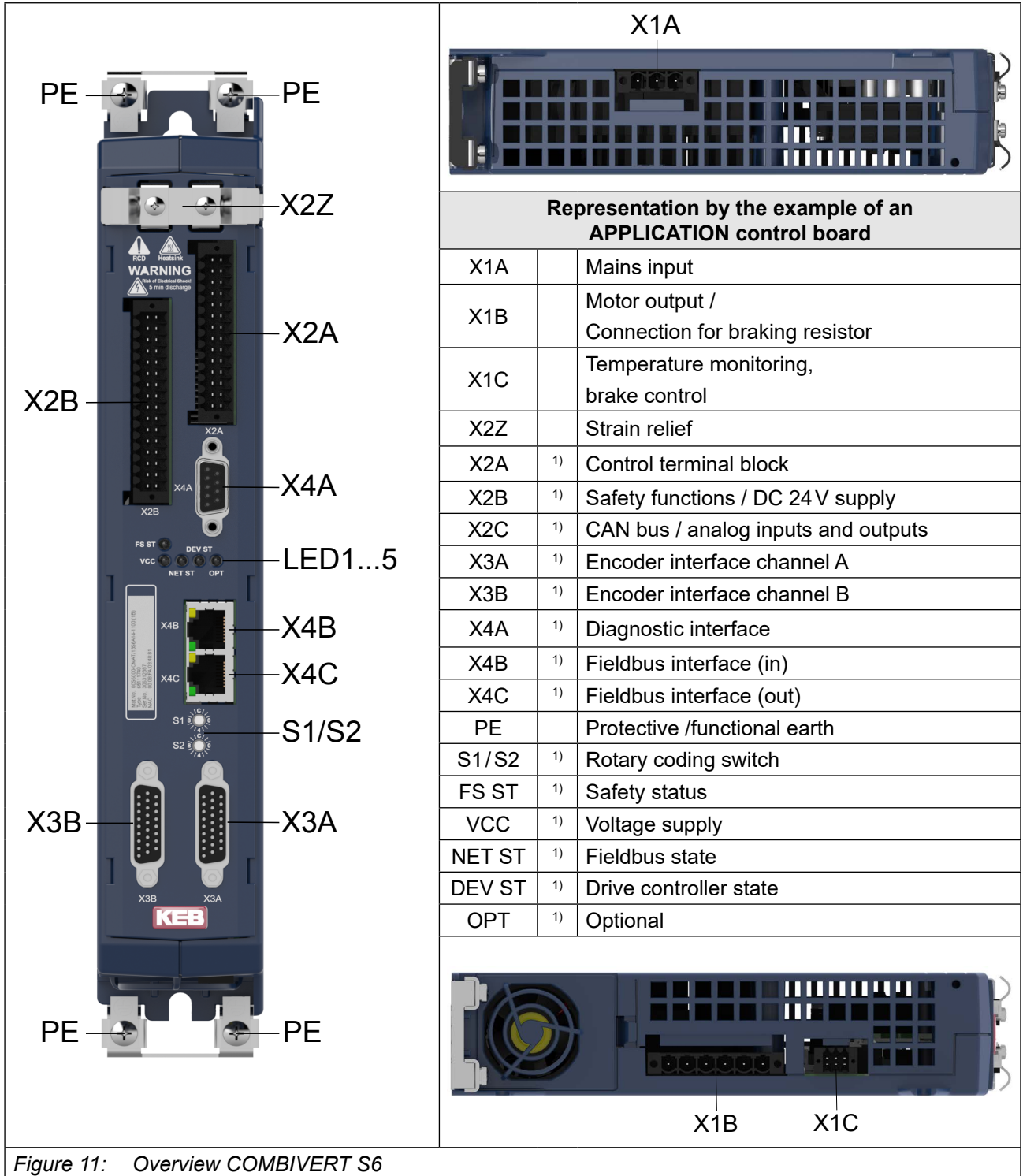

Figure 11: Overview COMBIVERT S6

<sup>1)</sup> Is described in the installation manual of the control board.



Instructions for use COMBIVERT S6 control board  
APPLICATION

[www.keb.de/fileadmin/media/Manuals/dr/ma\\_dr\\_s6-cu-a-inst-20109645\\_en.pdf](http://www.keb.de/fileadmin/media/Manuals/dr/ma_dr_s6-cu-a-inst-20109645_en.pdf)



Instructions for use COMBIVERT S6 control board  
COMPACT

[www.keb.de/fileadmin/media/Manuals/dr/ma\\_dr\\_s6-cu-k-inst-20087885\\_en.pdf](http://www.keb.de/fileadmin/media/Manuals/dr/ma_dr_s6-cu-k-inst-20087885_en.pdf)



Instructions for use COMBIVERT S6 control board  
PRO

[www.keb.de/fileadmin/media/Manuals/dr/ma\\_dr\\_s6-cu-p-inst-20156056\\_en.pdf](http://www.keb.de/fileadmin/media/Manuals/dr/ma_dr_s6-cu-p-inst-20156056_en.pdf)



## 4.2 Connection of the power unit

### 4.2.1 Connection of the voltage supply

#### 4.2.1.1 400V devices

The COMBIVERT S6 can be supplied both by mains and via DC terminals. The starting current limiting is arranged before the DC link. When using as DC output, parallel connected drive controllers must have their own starting current limiting at the DC voltage input.

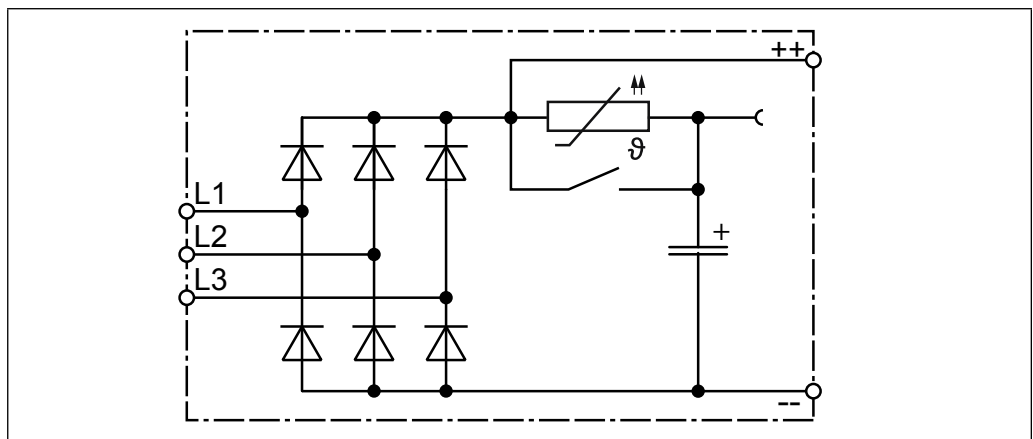

Figure 12: Input circuit/drive controller type 400 V devices

#### 4.2.1.2 230V devices

The COMBIVERT S6 can be supplied both by mains and via DC terminals. The starting current limiting is arranged before the DC link. When using as DC output, parallel connected drive controllers must have their own starting current limiting at the DC voltage input.

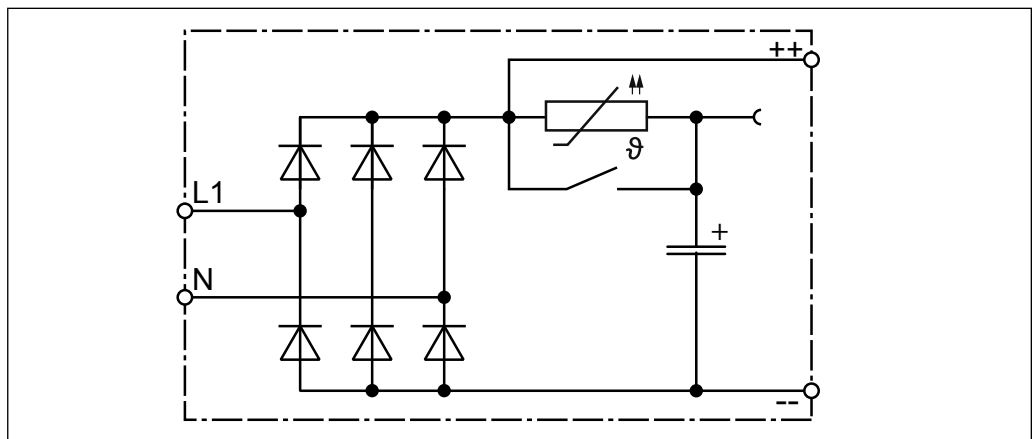

Figure 13: Input circuit/drive controller type 230 V devices

**NOTICE**



**Minimum waiting time between two switch-on procedures 5 minutes!**

Cyclic switching on and off of the unit leads to temporary high resistance of the resistor (PTC) in the input. A restart without limitation is possible after cooling.

**NOTICE**

**Destruction of the drive controller!**

Never exchange connections mains input and motor output!

4.2.1.3 Mains terminal block X1A

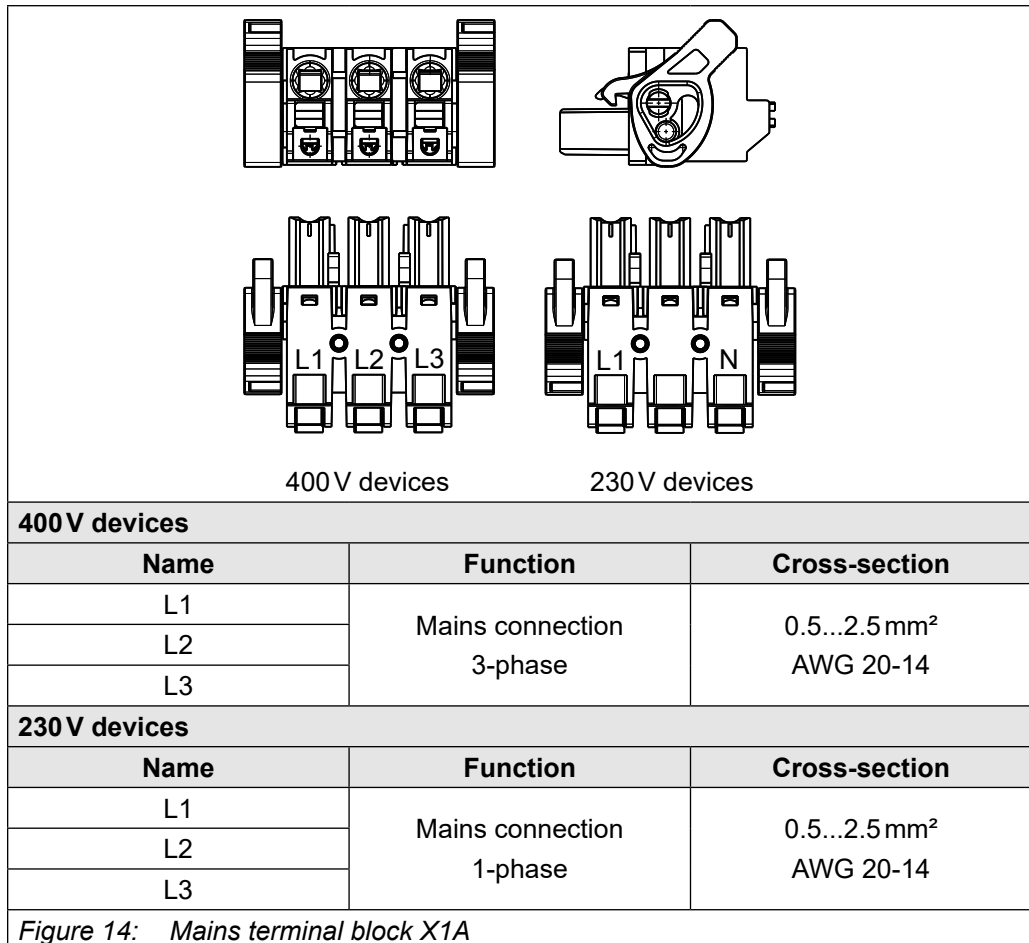

Figure 14: Mains terminal block X1A

**NOTICE**

**Pay attention to the connection cables!**

In UL-relevant applications, only multi-wire cables (strands) are permitted for devices of size 09 (1ph / 230V) at terminals X1A and X1B.

### 4.2.2 Leakage currents

Calculated maximum leakage currents depending on voltage and frequency.

Mains phases	Rated input voltage / V	Frequency / Hz	Leakage current / mA
1-phase	230	50	3.6
		60	4.3
	Maximum input voltage / V	Frequency / Hz	Leakage current / mA
	265	50	4.1
60		4.9	

Table 36: Leakage currents 1-phase

Mains phases	Rated input voltage / V	Frequency / Hz	Leakage current / mA
3-phase	230	50 / 60	<5
	400		

Table 37: Leakage currents 3-phase



The specified leakage currents are calculated values according to [DIN EN 60939-1](#). The real leakage currents may deviate from the calculated values depending on the network conditions.

### 4.2.3 Protective earth and functional earth



Protective and functional earth must not be connected to the same terminal.

#### 4.2.3.1 Protective earth

The protective earth (PE) serves for electrical safety particularly personal protection in error case.



**Electric shock due to incorrect dimensioning!**



► Cross-section wire to ground should be selected according to [DIN IEC 60364-5-54](#)!

Name	Function	Terminal connection	Tightening torque
PE, ⊕	Connection for protective earth	Screw M4 for crimp connector	1.3 Nm 11 lb inch

Figure 15: Connection for protective earth

### 4.2.3.2 Functional earthing

A functional earthing may also be necessary, if for EMC requirements additional potential equalization between devices or parts of the system must be available.



The use of the functional earth (FE) is not required if the frequency inverter is EMC-technically wired.

The functional earth may not be wired green/yellow!

---



Notes on EMC-compatible installation can be found here.  
[www.keb.de/fileadmin/media/Manuals/emv/0000neb0000.pdf](http://www.keb.de/fileadmin/media/Manuals/emv/0000neb0000.pdf)





4.2.4 AC connection

4.2.4.1 AC supply 230V/400V 3-phase

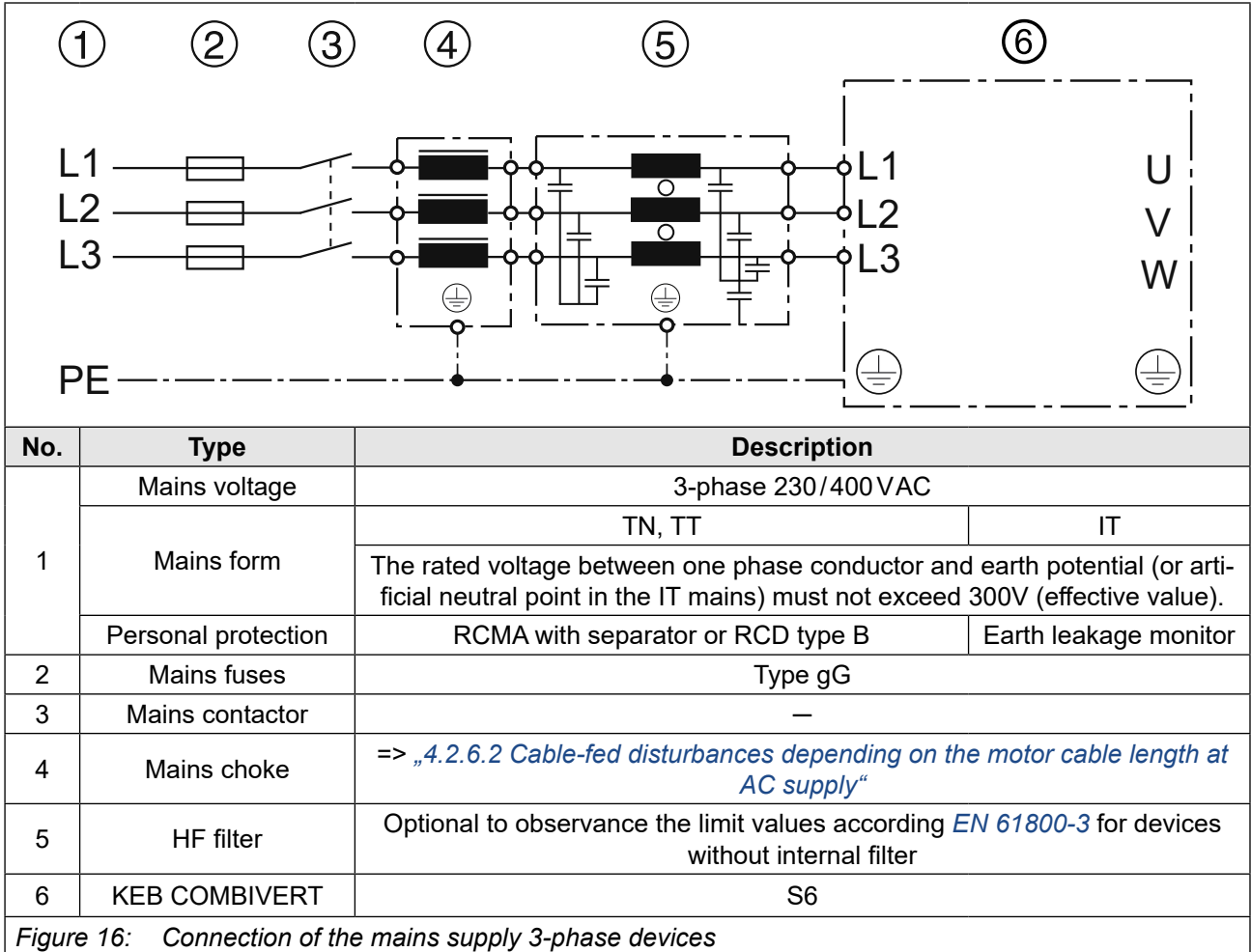

Figure 16: Connection of the mains supply 3-phase devices

The service life of drive controllers with voltage DC link depends on the DC voltage, surrounding temperature and the current load of the electrolytic capacitors in the DC link. The use of mains chokes can increase the service life of the condensators to a considerable extent, especially when connecting to „hard“ power systems or under permanent drive load (continuous duty). The term "hard" power system means that the nodal point power ( $S_{net}$ ) of the mains is very high ( $\gg 200$ ) compared to the rated apparent output power of the drive controller ( $S_{out}$ ).

$k = \frac{S_{net}}{S_{out}} \gg 200$	e.g.	$k = \frac{2 \text{ MVA (supply transformer)}}{4 \text{ kVA (10S6)}} = 500 \rightarrow \text{Choke required}$
---------------------------------------	------	---

## CONNECTION OF THE POWER UNIT

### 4.2.4.2 AC supply 230V 1-phase

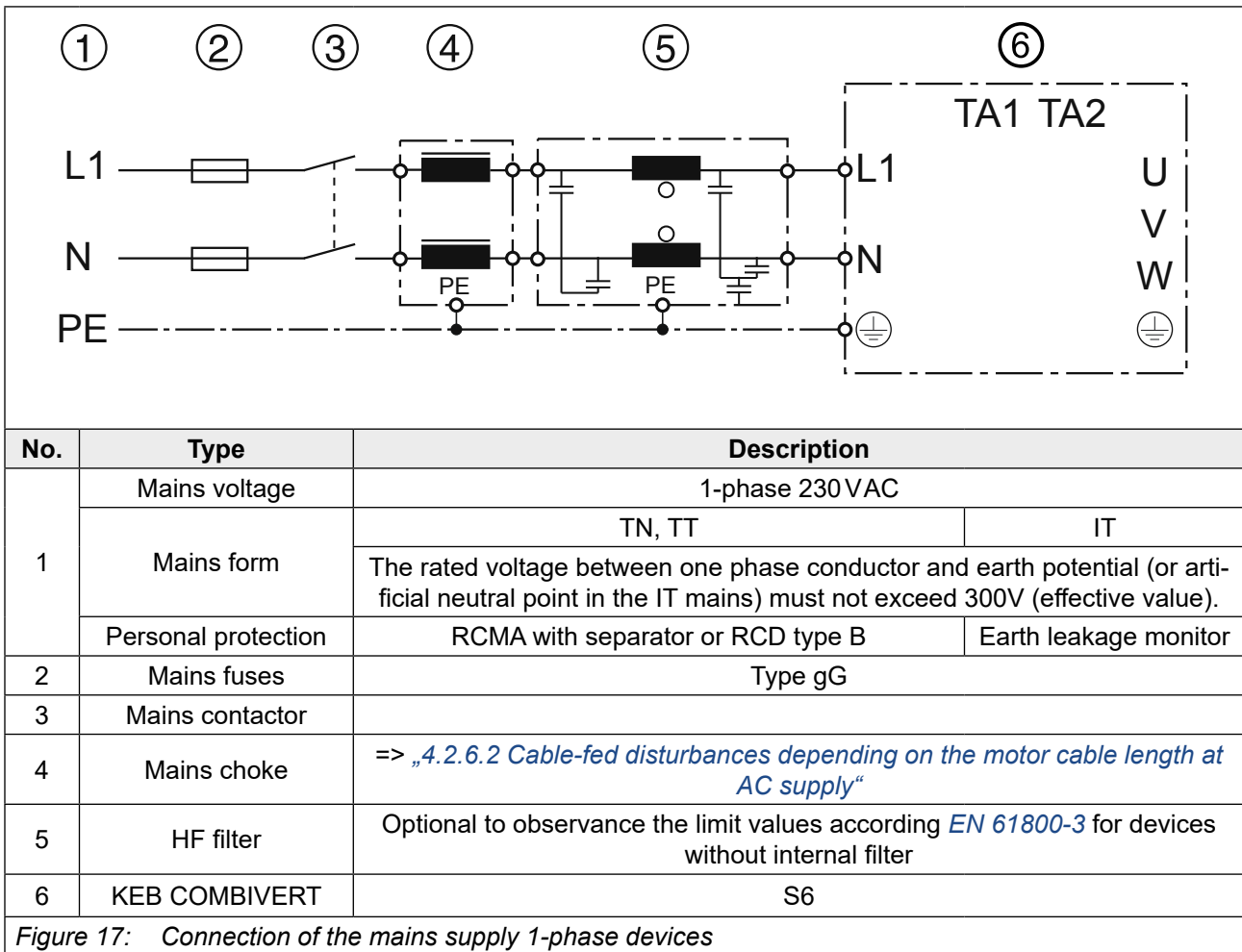

Figure 17: Connection of the mains supply 1-phase devices

The service life of drive controllers with voltage DC link depends on the DC voltage, surrounding temperature and the current load of the electrolytic capacitors in the DC link. The use of mains chokes can increase the service life of the condensators to a considerable extent, especially when connecting to „hard“ power systems or under permanent drive load (continuous duty). The term "hard" power system means that the nodal point power ( $S_{net}$ ) of the mains is very high ( $\gg 200$ ) compared to the rated apparent output power of the drive controller ( $S_{out}$ ).

$k = \frac{S_{net}}{S_{out}} \gg 200$	e.g.	$k = \frac{2 \text{ MVA (supply transformer)}}{2.8 \text{ kVA (09S6)}} = 714 \rightarrow \text{Choke required}$
---------------------------------------	------	---

4.2.4.3 Supply cable

The conductor cross-section of the supply line is determined by the following factors:

- Input current of the drive controller
- Used cable type
- Installation method and ambient temperature
- The locally valid electrical regulations



The project engineer is responsible for the design!

4.2.5 DC connection

4.2.5.1 Connection at DC voltage supply

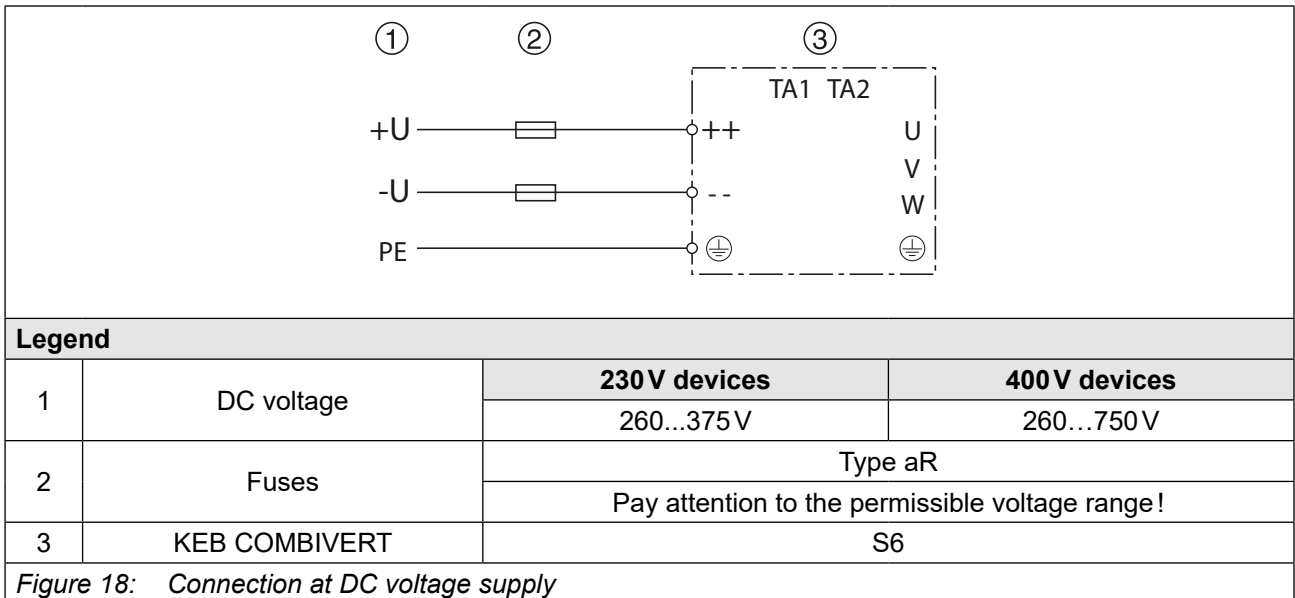

Figure 18: Connection at DC voltage supply

4.2.5.2 Terminal block X1B DC connection

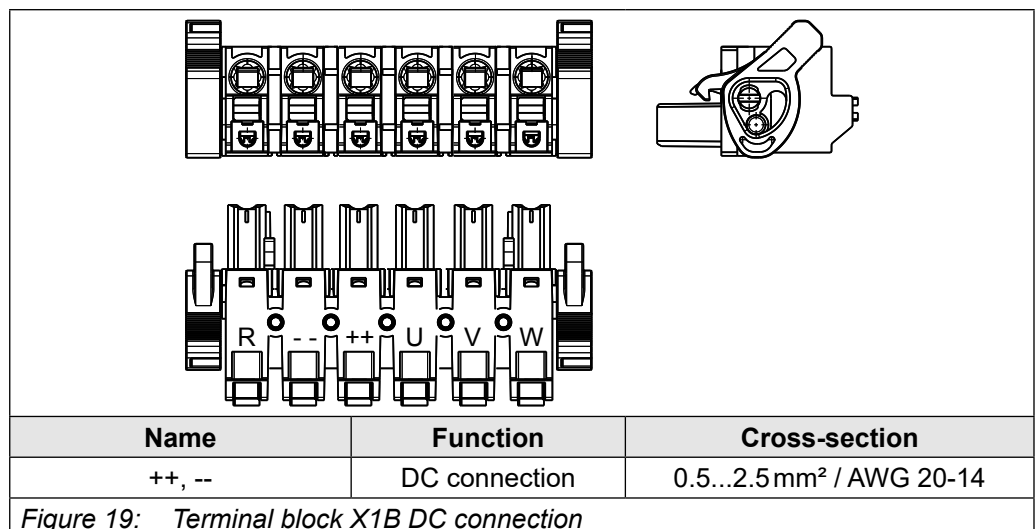

Figure 19: Terminal block X1B DC connection

4.2.6 Connection of the motor

4.2.6.1 Selection of the motor cable

The correct cabling as well as the motor cable plays an important part in case of low power in connection with long motor cable lengths. Ferrite cores and low-capacitance cables (phase/phase < 65 pF/m, phase/screen < 120 pF/m) at the output have the following effects:

- longer motor cable lengths
- less abrasion of the motor gearbox by leakage currents
- better EMC properties (reduction of the common-mode output currents to earth)

4.2.6.2 Cable-fed disturbances depending on the motor cable length at AC supply

The maximum motor cable length is depending on the capacity of the cable as well as on the EMC emitted interference. The following data apply for operation under nominal rating conditions.

Voltage class	Device size	Max. motor cable length (shielded) in accordance with EN 61800-3 Category C2 Motor cable / m (low-capacitance)
230 V 1-phase	07	30
	09	
400 V 3-phase	07	50
	09	
	10	

Table 38: Maximum motor cable length at AC supply



The use of motor chokes or filters can significantly increase the cable length. KEB recommends the use of motor chokes or filters for a line length upto 50 m. Motor chokes or filters are absolutely necessary upto 100 m.

4.2.6.3 Motor cable length at operation with DC voltage

The maximum motor cable length at DC operation is basically dependent on the capacity of the motor cable. The internal filter is not active at DC operation. External measures must be taken if necessary. The following data apply for operation under nominal rating conditions.

Voltage class	Device size	Motor cable / m (low-capacitance)
230 V 1-phase	07	50
	09	
400 V 3-phase	07	50
	09	
	10	

Table 39: Maximum motor cable length at DC operation

4.2.6.4 Motor cable length for parallel operation of motors

The resulting motor cable length for parallel operation of motors, or parallel installation with multiple cables arises from the following formula:

$$\text{resulting motor cable length} = \sum \text{single cable length} \times \sqrt{\text{Number of motor cables}}$$

4.2.6.5 Motor cable cross-section

- The motor cable cross-section is dependent
- on the characteristic of the output current (e.g. not sine-wave).
  - on the real effective value of the motor current.
  - on the cable length.
  - on the type of the used cable.
  - on the ambient conditions such as bundling and temperature.

4.2.6.6 Interconnection of the motor

**NOTICE**

**Protect motor against voltage peaks !**

Drive controllers switch at the output with  $dV / dt \leq 5kV/\mu s$ . Voltage peaks that endanger the insulation system at the motor can occur especially in case of long motor cables (> 15 m). A motor choke, a dv/dt-filter or sine-wave filter can be used for protection of the motor.

**NOTICE**

**Faulty behaviour of the motor !**

The connecting-up instructions of the motor manufacturer are always generally valid !

4.2.6.7 Terminal block X1B motor connection

Name	Function	Cross-section
U, V, W	Motor connection	0.5...2.5mm <sup>2</sup> / AWG 20-14

Figure 20: Terminal block X1B motor connection

4.2.6.8 Wiring of the motor

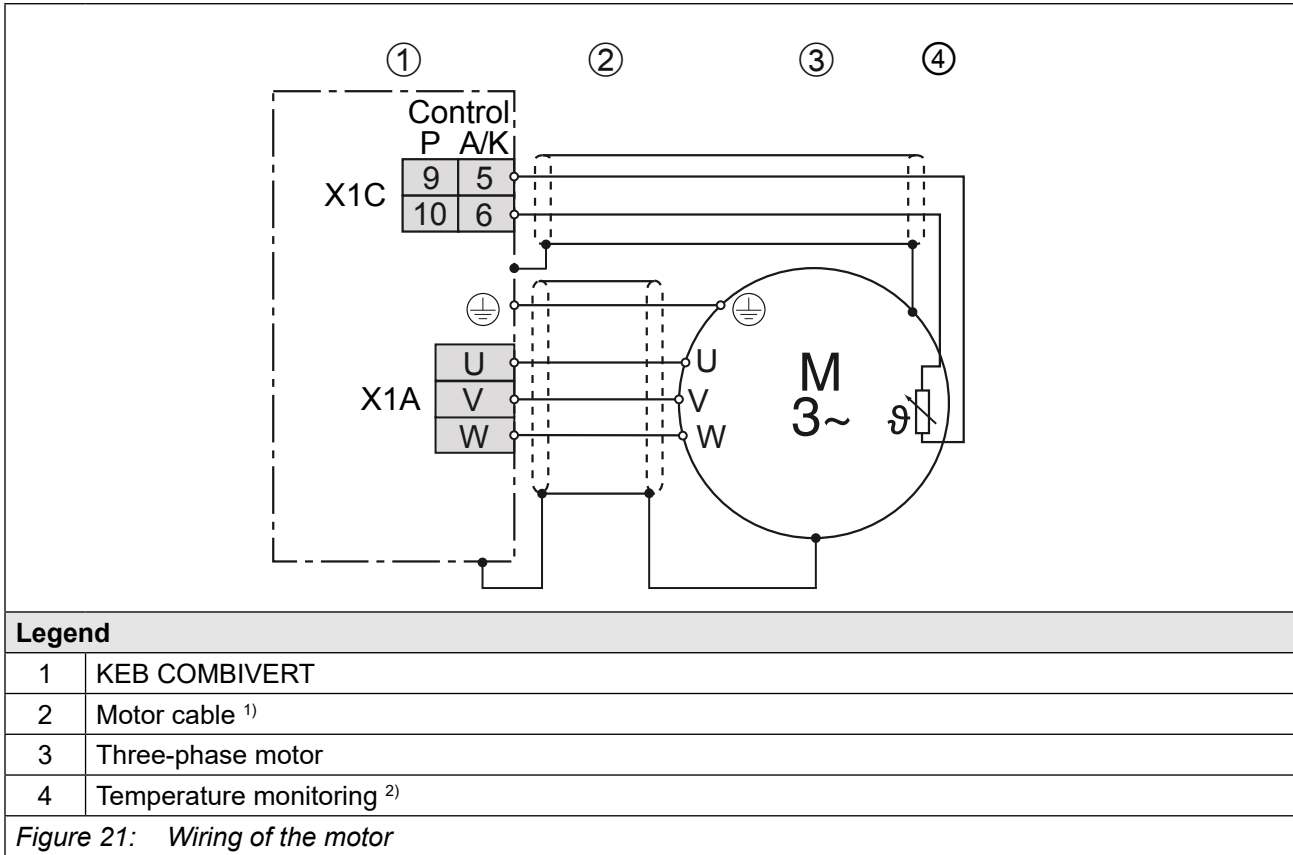

<sup>1)</sup> Apply the shield at both ends over a large area on the functional earth (shielding plate or mounting plate)

<sup>2)</sup> Temperature monitoring is optionally available, => *Instructions for use „Control unit“*.

**NOTICE**

**Connection of the temperature monitoring**

- Do not lay the connection cable of the motor temperature detection (also shielded) together with the control cable !
- The connection cable of the temperature detection inside the motor cable is only permissible with additional shielding (double shielding)!
- The input of the temperature detection has basic isolation.

4.2.7 Connection of a braking resistor

**⚠ CAUTION**

**Not fall below the minimum braking resistor value!**

Falling below the minimum braking resistor value destroys the braking transistor of the drive controller.

4.2.7.1 Terminal block X1B connection braking resistor

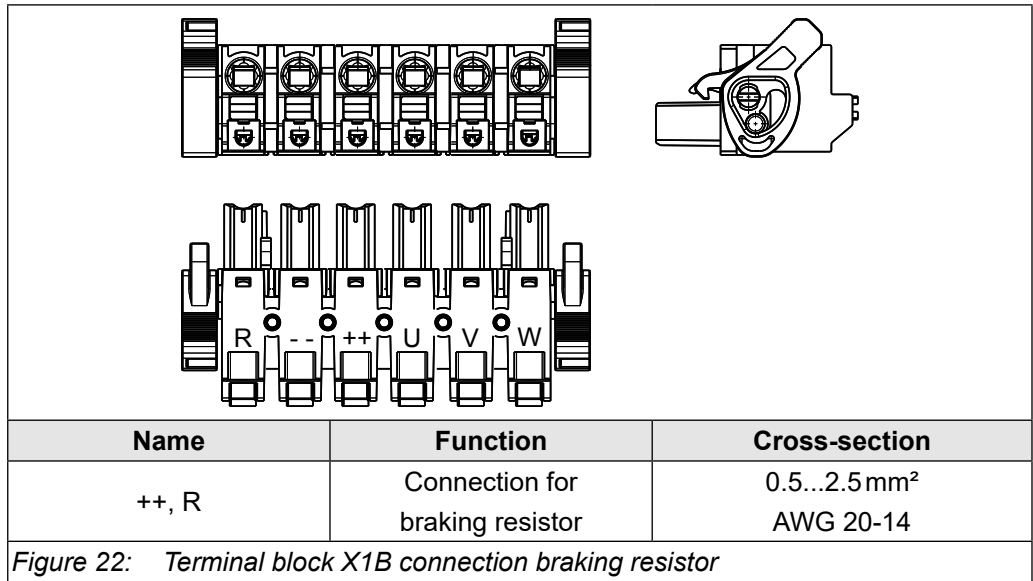

The figure shows three views of the terminal block X1B: a top view, a side view, and a front view. The front view labels the terminals from left to right as R, --, ++, U, V, and W. Below the diagrams is a table with the following content:

Name	Function	Cross-section
++, R	Connection for braking resistor	0.5...2.5mm <sup>2</sup> AWG 20-14

Figure 22: Terminal block X1B connection braking resistor

4.2.7.2 Use of intrinsically safe braking resistors

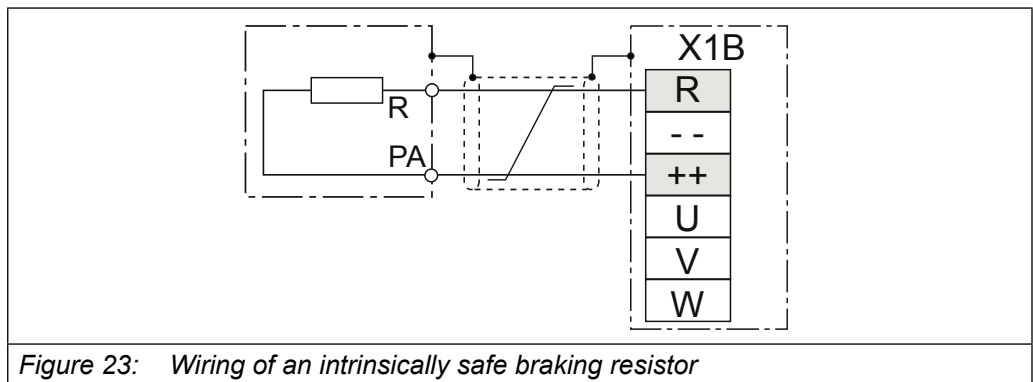

**NOTICE**

**Only intrinsically safe braking resistors permitted!**

Only "intrinsically safe" braking resistors are permitted for this operation, since these resistors interrupt themselves at fault such as safety fuse without fire risk.



Instructions for use „Installation of an intrinsically safe braking resistor“

[www.keb.de/fileadmin/media/Manuals/dr/ma\\_dr\\_safe-braking-resistors-20106652\\_en.pdf](http://www.keb.de/fileadmin/media/Manuals/dr/ma_dr_safe-braking-resistors-20106652_en.pdf)



4.2.7.3 Use of non-intrinsically safe braking resistors

**⚠ WARNING**



**Use of non-intrinsically safe braking resistors**

**Fire or smoke development in case of overload or fault!**

- ▶ Only use braking resistors with temperature sensor.
- ▶ Evaluate temperature sensor.
- ▶ Trigger fault on the drive controller (e.g. external input).
- ▶ Switch off input voltage (e.g. input contactor).
- ▶ Connection examples for non-intrinsically safe braking resistors  
=> *Instructions for use „Installation Braking Resistors“.*



Instructions for use „Installation Braking Resistors“  
[www.keb.de/fileadmin/media/Manuals/dr/ma\\_dr\\_braking-resistors-20116737\\_en.pdf](http://www.keb.de/fileadmin/media/Manuals/dr/ma_dr_braking-resistors-20116737_en.pdf)





### 4.3 Brake control and temperature detection for K- and A- control

X1C	PIN	Name	Notes
	1	BR+	Brake control / output +
	2	BR-	Brake control / output -
	3	Reserved	
	4	Reserved	
	5	TA1	Temperature detection / input+
	6	TA2	Temperature detection / input-

Figure 24: Assignment of the terminal block X1C for K- and A-control

#### 4.3.1 Specification and connection of the brake control

	
<b>Name</b>	BR+ (X1C.1); BR- (X1C.2)
<b>Function</b>	Output to supply a brake
<b>Output voltage</b>	<ul style="list-style-type: none"> <li>Minimum P24V_IN - 2.4 V</li> <li>Maximum P24V_IN</li> </ul>
<b>Maximum output current</b>	2A
<b>Others</b>	Short-circuit proof, internal free-wheeling path; internal filter switching

Figure 25: Example for the connection of the brake output at X1C

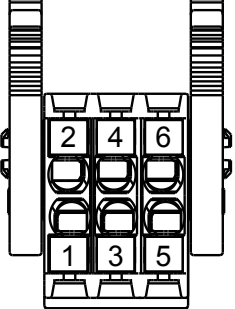
**4.3.2 Specification and connection of the temperature detection**

**⚠ DANGER**

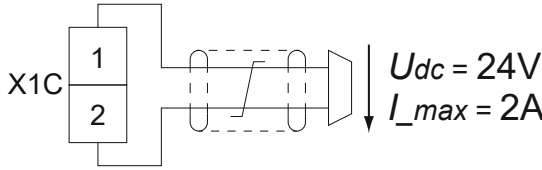

**Use only sensors with basic insulation to mains potential !**

**Danger to life due to electric shock !**

- ▶ The inputs of the temperature detection have „basic insulation“ against SELV voltage of the control.
- ▶ A system voltage (Phase – PE) of 300V is defined.

**NOTICE**

**Malfunctions due to incorrect cable or laying!**

**Malfunctions of the control due to capacitive or inductive coupling.**

- ▶ Do not lay cables of the motor temperature sensor (also shielded) together with the control cable!
- ▶ Cables of the motor temperature sensor inside the motor cable only permissible with double shielding!

A switchable KTY84/PTC evaluation is implemented in the KEB COMBIVERT. The desired operating mode can be adjusted by software (dr33).

Operating mode (dr33)		Resistance	Temperature / state
0	KTY84/130	0.49 kΩ	0°C
		1 kΩ	100°C
		1.72 kΩ	200°C
1	PTC in accordance with <i>EN 60947-8</i> (standard)	< 0.75 kΩ	TA1-TA2 closed
		0.75...1.5 kΩ	Reset resistance
		1.65...4 kΩ	Tripping resistance
		> 4 kΩ	TA1-TA2 open
2	By encoder	digital by the encoder channel	
3	KTY83/110	0.82 kΩ	0°C
		1.67 kΩ	100°C
		2.53 kΩ	175°C
4	PT1000	1 kΩ	0°C
		1.38 kΩ	100°C
		1.75 kΩ	200°C
—	Monitoring	< 0,04 kΩ	Short circuit
		> 79,5 kΩ	No connection (sensor break)

*Table 40: Specification of the temperature input for K- and A-control*

### 4.3.3 Operation without temperature detection

Use of the COMBIVERT without evaluation of the temperature input:

- Deactivate the evaluation (pn33 =7)
- or
- Install bridge between terminal X1C.5 and X1C.6 (dr33=1)

### 4.3.4 Connection of a KTY sensor

#### NOTICE

**No protection of the motor winding in case of wrong connection.**

- ▶ Operate KTY sensors in forward direction. Non-observance leads incorrect measurement in the upper temperature range.
- ▶ KTY sensors may not be combined with other detections.

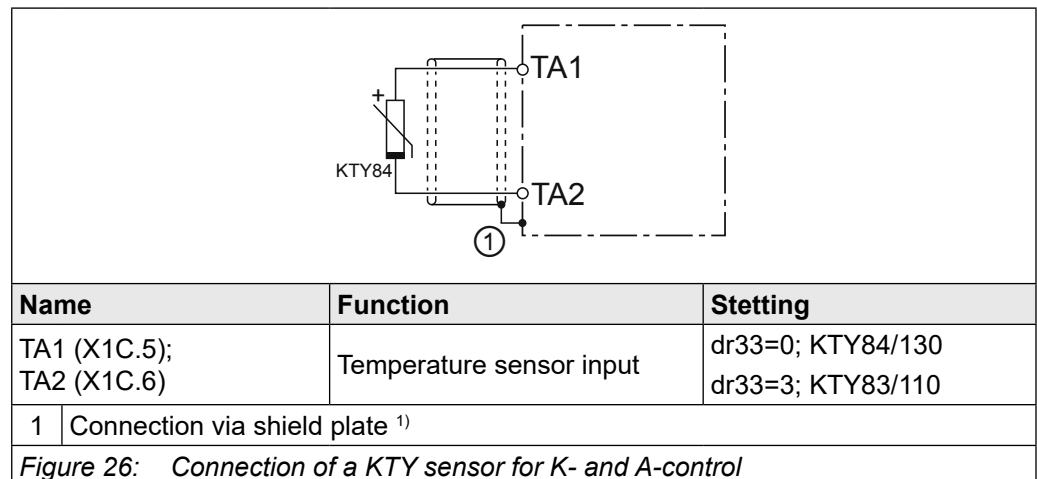

Figure 26: Connection of a KTY sensor for K- and A-control

<sup>1)</sup> If not available, place on the mounting plate.

**4.3.5 Connection of PTC, temperature switch or PT1000**

Thermal contact (NC contact)		
Temperature sensor (PTC) or PT1000		
Mixed sensor chain		
Name	Function	Setting
TA1 (X1C.5); TA2 (X1C.6)	Temperature sensor input	dr33=1; PTC or temperature switch dr33=4; PT1000
1	Connection via shield plate <sup>1)</sup>	
<i>Figure 27: Connection examples of different temperature sensors K/A</i>		

<sup>1)</sup> If not available, place on the mounting plate.

#### 4.4 Brake control and temperature detection for P- control

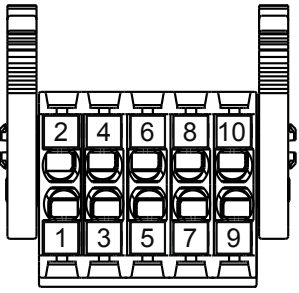
X1C	PIN	Name	Notes
	1	BR+	Brake control / output
	2	BR-	Brake control / output
	3	0V	for supply of the feedback inputs P24Vin - 0.5V / max. 1A
	4	24Vout	(BR+ and 24Vout in addition 2A)
	5	DIBR1	feedback input for brake control
	6	DIBR2	feedback input for brake control
	7/8	reserved	
	9	TA1	Temperature detection / input+
	10	TA2	Temperature detection / input-

*Figure 28: Assignment of the terminal block X1C for P-control*

##### 4.4.1 Specification and connection of the brake / relay control

Features of the control

- safely control one brake/relay
- control together two single brakes/relays; it must be the same brake/relay twice.
- Internal brake feedback without additional wiring or external via two digital brake inputs.
- Power reduction through pulse width modulated control.
- Rapid demagnetization with a counter voltage of 27.5V, maximum every 5s
- Current monitoring

The control, parameterization and reading of the feedback inputs of the brake is carried out via the integrated safety module. Corresponding wiring and parameterization suggestions are described in the safety manual type 5.

<b>Name</b>	BR+ (X1C.1); BR- (X1C.2)
<b>Function</b>	Output for control one/two brake(s) or relay(s)
<b>DC output voltage</b>	Minimum P24Vin - 1,2V Maximum P24Vin
<b>Maximum braking current</b>	one brake: 2A two brakes: 2 x 1A
<b>Others</b>	Internal free-wheeling path; internal filter circuit; not short-circuit proof

*Table 41: Specification of the brake control for P-control*

### NOTICE

#### Using a brake

- Choose the input voltage tolerance of the brake corresponding to the tolerance of the output voltage.

## 4.4.2 Specification and connection of the temperature detection

**⚠ DANGER**

Use only sensors with base insulation or safe separation!

Danger to life due to electric shock!

**NOTICE**

**Malfunctions due to incorrect cable or laying!**

**Malfunctions of the control due to capacitive or inductive coupling.**

- ▶ Do not lay cables of the motor temperature sensor (also shielded) together with the control cable!
- ▶ Cables of the motor temperature sensor inside the motor cable only permissible with double shielding!

A switchable KTY84/PTC evaluation is implemented in the COMBIVERT. The desired operating mode can be adjusted by software (dr33).

Operating mode (dr33)		Resistance	Temperature / state
0	KTY84/130	0.49 kΩ	0°C
		1 kΩ	100°C
		1.72 kΩ	200°C
1	PTC in accordance with <i>EN 60947-8</i> (standard)	< 0.75 kΩ	TA1-TA2 closed
		0.75...1.5 kΩ	Reset resistance
		1.65...4 kΩ	Tripping resistance
		> 4 kΩ	TA1-TA2 open
2	By encoder	digital by the encoder channel	
3	KTY83/110	0.82 kΩ	0°C
		1.67 kΩ	100°C
		2.53 kΩ	175°C
4	PT1000	1 kΩ	0°C
		1.38 kΩ	100°C
		1.75 kΩ	200°C
—	Monitoring	< 0,04 kΩ	Short circuit
		> 79,5 kΩ	No connection (sensor break)

Table 42: Specification of the temperature input for P-control

## 4.4.2.1 Operation without temperature detection

Use of the COMBIVERT without evaluation of the temperature input:

- Deactivate the evaluation (pn12=7).

or

- Install bridge between terminal TA1 (X1C.9) and TA2 (X1C.10) (dr33=1).

## 4.4.2.2 Connection of a KTY sensor

**NOTICE**

**No protection of the motor winding in case of wrong connection.**

- ▶ Operate KTY sensors in forward direction. Non-observance leads incorrect measurement in the upper temperature range.
- ▶ KTY sensors may not be combined with other detections.

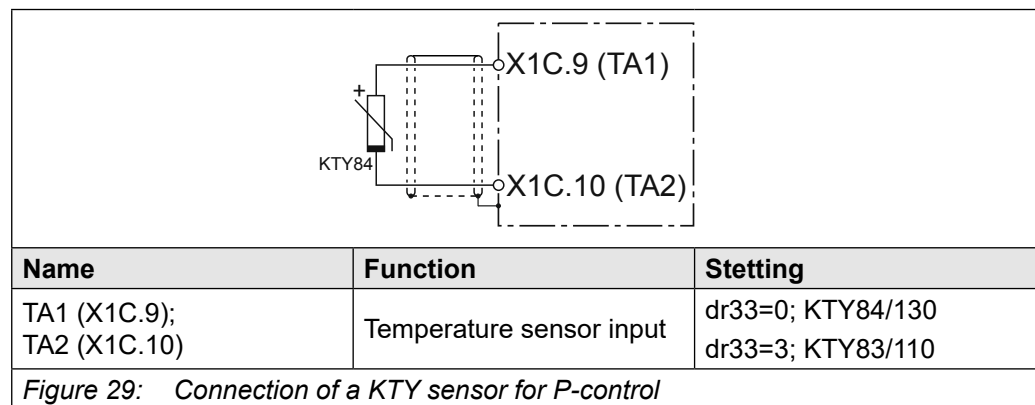

4.4.2.3 Connection of PTC, temperature switch or PT1000

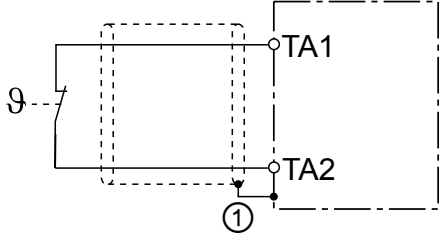
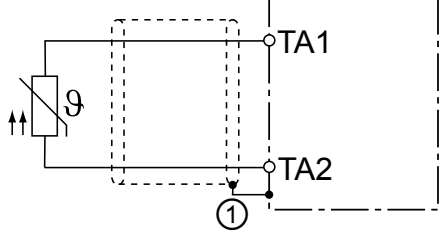
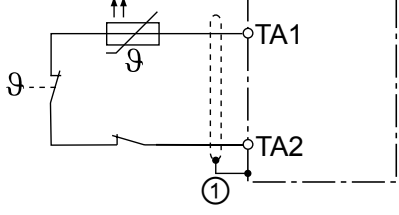
Thermal contact (NC contact)		
Temperature sensor (PTC) or PT1000		
Mixed sensor chain		
Name	Function	Stetting
TA1 (X1C.9); TA2 (X1C.10)	Temperature sensor input	dr33=1; PTC or tempera- ture switch dr33=4; PT1000
1	Connection via shield plate <sup>1)</sup>	
<i>Figure 30: Connection examples of different temperature sensors for P-control</i>		

<sup>1)</sup> If not available, place on the mounting plate.



## 5 Certification

### 5.1 CE-Marking

CE marked drive controllers have been developed and manufactured to comply with the regulations of the Low-Voltage Directive and EMC directive. The harmonized standards of the series [EN 61800-5-1](#) and [EN 61800-3](#) were used.



Further information can be found in the download area of [www.keb.de](http://www.keb.de) under the search term „Declaration of conformity“.

### 5.2 Functional safety

Drive controllers with functional safety are marked with the FS logo on the nameplate. These devices are designed and manufactured in accordance with the Machine Directive. The harmonized standard of the series [EN 61800-5-2](#) is used.

### 5.3 Annex to the declaration of conformity

Annex to the EC declaration of conformity for systems with functional safety:

Product designation:	Drive controller - series	xxS6xxx-xxxx
	Dimension	07 - 14
	Voltage class	200 V / 400 V

Hereby we declare that the safety component specified above complies with all relevant regulations of the machine directive.

The safety component specified above meets the requirements of the following guidelines and standards:

•	Machine directive	2006/42/EC
•	EMC directive	2014/30/EU
•	Low-Voltage Directive	2014/35/EU
•	Hazardous substances	2011/65/EU

## ANNEX TO THE DECLARATION OF CONFORMITY

EN - Norm	Name	Reference
EN61800-5-1	Electrical power drive systems with adjustable speed: Safety requirements	VDE 0160-105-1
EN61800-2	Basic determinations for AC drive controller	VDE 0160-102
EN61800-3	Electrical power drive systems with adjustable speed. EMC requirements	VDE 0160-103
Especially for systems with functional safety additionally:		
EN61800-5-2	Electrical power drive systems with adjustable speed: functional safety requirements	VDE 0160-105 -2
EN61508-(1...7)	Functional safety of electrical/electronic programmable electronic safety-related systems	VDE 0803-1 ...7
EN 60204-1	Safety of machinery - Electrical equipment of machines Part1: General requirements	VDE 0113-1
EN62061	Safety of machinery - Functional safety of electrical, electronic and programmable electronic control systems	VDE 0113 -50
EN 13849-1	Safety of machinery - Safety-related parts of control systems	–
<i>Table 43: Applied standards</i>		

The conformity was confirmed by the TÜV Rheinland with the EC-type examination certificate 01/205/5421.00/14.

The number/address of the indicated constitution:

NB 0035

TÜV Rheinland Industrie Service GmbH

Alboinstr. 56,

12103 Berlin

Germany

Tel.: +49 30 7562-1557

Fax: +49 30 7562-1370

E-Mail: [tuvat@de.tuv.com](mailto:tuvat@de.tuv.com)

### 5.4 UL Marking

	<p>Acceptance according to UL is marked at KEB drive controllers with the adjacent logo on the nameplate.</p>
--	---

To be conform according to UL for use on the North American and Canadian Market the following additionally instructions must be observed (original text of the UL-File):

<ul style="list-style-type: none"> <li>• Only for use in grounded WYE supply sources.</li> </ul>
<ul style="list-style-type: none"> <li>• Rating of relays on Control Board A or Control Board K (30Vdc.:1A).</li> </ul>
<ul style="list-style-type: none"> <li>• Maximum Surrounding Air Temperature 45°C.</li> </ul>
<ul style="list-style-type: none"> <li>• Internal Overload Protection Operates prior to reaching the 200% of the Motor Full Load Current.</li> </ul>
<ul style="list-style-type: none"> <li>• S6, Housing Size 2 (1 phase Models 07S6 and 09S6): Suitable For Use On A Circuit Capable Of Delivering Not More Than 5000 rms Symmetrical Amperes, yyy Volts Maximum when protected by CC or J Class Fuses or by a Manual Motor Controller,type E as specified in the instruction manual</li> </ul> <p>S6, Housing Size 2 (1 phase Models: 07S6 and 09S6): Suitable For Use On A Circuit Capable Of Delivering Not More Than 30000 rms Symmetrical Amperes, yyy Volts Maximum when protected by CC Class Fuses as specified in the instruction manual</p> <p>S6, Housing Size 2(3 phase Models: 07S6, 09S6 and 10S6): Suitable For Use On A Circuit Capable Of Delivering Not More Than 30000 rms Symmetrical Amperes, xxx Volts Maximum when protected by CC Class Fuses or by Manual Motor Controllers type E „, see instruction manual for Branch Circuit Protection details.</p> <p>S6, Housing Size 2 (3 phase Models: 07S6, 09S6 and 10S6):„Suitable For Use On A Circuit Capable Of Delivering Not More Than 5000 rms Symmetrical Amperes, 480 Volts Maximum when protected by Circuit Breakers“, see instruction manual for Branch Circuit Protection details „.</p> <p>Where: xxx = 230V for 200-230V models and 480V for 480V models yyy = 120V for 120V models and 230V for 230V models</p>
<ul style="list-style-type: none"> <li>• Integral solid state short circuit protection does not provide branch circuit protection. Branch circuit protection must be provided in accordance with the Manufacturer Instructions, National Electrical Code, the Canadian Electrical code, part I, and any additional local codes.</li> </ul>
<ul style="list-style-type: none"> <li>• Use in a Pollution Degree 2 environment.</li> </ul>
<ul style="list-style-type: none"> <li>• Terminals X1A/X1B: Housing size 2, model 09S6, single phase 230V units: “only for use with stranded wires”</li> </ul>
<ul style="list-style-type: none"> <li>• Use 60/75°C Copper Conductors Only.</li> </ul>
<ul style="list-style-type: none"> <li>• During the UL evaluation, only Risk of Electrical Shock and Risk of Fire aspects were investigated. Functional Safety aspects were not evaluated.</li> </ul>
<p><i>continued on the next page</i></p>

<ul style="list-style-type: none"> <li>Wiring Terminals marked to indicate proper connections for the power supply, load and control circuit.</li> </ul>
<ul style="list-style-type: none"> <li>WARNING – The opening of the branch circuit protective device may be an indication that a fault current has been interrupted. To reduce the risk of fire or electrical shock, current-carrying parts and other components of the controller should be examined and replaced if damaged. If burnout of the current element of an overload relay occurs, the complete overload relay must be replaced.</li> </ul> <p>AVERTISSEMENT – LE DÉCLENCEMENT DU DISPOSITIF DE PROTECTION DU CIRCUIT DE DÉRIVATION PEUT ÊTRE DÛ À UNE COUPURE QUI RÉSULTE D'UN COURANT DE DÉFAUT. POUR LIMITER LE RISQUE D'INCENDIE OU DE CHOC ÉLECTRIQUE, EXAMINER LES PIÈCES PORTEUSES DE COURANT ET LES AUTRES ÉLÉMENTS DU CONTRÔLEUR ET LES REMPLACER S'ILS SONT ENDOMMAGÉS. EN CAS DE GRILLAGE DE L'ÉLÉMENT TRAVERSÉ PAR LE COURANT DANS UN RELAIS DE SURCHARGE, LE RELAIS TOUT ENTIER DOIT ÊTRE REMPLACÉ.</p>

Devices 07, 09 and 10 / 480V – housing 2 have been evaluated for connecting to DC voltage, supplied by other KEB inverters to a DC bus capacitance as follows:

Cat. No.	Housing	Min. capacitance	Max. capacitance
07S6	02	235uF	18600 uF
09S6			
10S6			

Cat. No.	Housing	DC voltage	Full Load Current
07S6	02	680 V	3.6 A
09S6			5.8 A
10S6			8 A

Branch Circuit Protection for series S6 housing size 2

I) Class CC fuses; not more than 30000 rms Symmetrical Amperes (SCCR 30kA):

Cat. No.	Housing	Input Voltage [Vac]	maximum Fuse size [A]
07S6	02	200-230 / 3ph	6
09S6			10
10S6		480 / 3ph	10

The voltage rating of the external fuses shall be at least equal to the input voltage of the drives.

Class CC or Class J, not more than 5000 rms Symmetrical Amperes (SCCR 5000):

Class CC not more than 30000 rms Symmetrical Amperes (SCCR 30000):

Cat. No.	Housing	Input Voltage [Vac]	maximum Fuse size [A]
07S6	02	120-230 / 1ph	15
09S6			20

II) Listed (NKHJ, NKHJ7/CSA Certified), Type E Self Protected Manual Motor Controllers, Type and manufacturer and electrical ratings as specified below:

120-230V/1ph S6 Models:

Manual Motor Controller; not more than 5000 rms Symmetrical Amperes (SCCR 5kA):

Cat. No.	Housing	Manufacturer	Type	Rating
07S6	02	Eaton	PKZM0 20-E	115V/1ph, 1.5 hp
09S6				230V/1ph, 3hp

200-230V/3ph S6 Models:

Manual Motor Controller; not more than 30000 rms Symmetrical Amperes (SCCR 30kA):

Cat. No.	Housing	Manufacturer	Type	Rating
07S6	02	Eaton	PKZM0 10-E	200V-230V/3ph, 3 hp
09S6				
10S6				

480V Models/3ph S6 Models:

Manual Motor Controller; not more than 30000 rms Symmetrical Amperes (SCCR 30kA):

Cat. No.	Housing	Manufacturer	Type	Rating
07S6	02	Eaton	PKZM0 10-E	480Y/277V/3ph, 7.5 hp
09S6				
10S6				

III) Listed (DIVQ, DIVQ7/CSA Certified), Listed Circuit Breaker, Type and manufacturer and electrical ratings as specified below:

480V Models/3ph S6 Models:

Cat. No.	Housing	Manufacturer	Type	Rating
07S6	02	Siemens	5SJ4310-7HG42	480Y/277Vac 10A
09S6				
10S6				

Following models were investigated for use with DC supply at their DC terminals:

DC Circuit Protection for series S6 housing size 2

480V/3ph Models:

Cat. No.	Housing	Manufacturer	Type	Rating
07S6	02	SIBA	50 118 06.08	700V / 8A
09S6			50 118 06.12	700V / 12A
10S6			50 118 06.16	700V / 16A

## 5.5 Further informations and documentation

You find supplementary manuals and instructions for the download under [www.keb.de/de/service/downloads](http://www.keb.de/de/service/downloads)

### General instructions

- EMC and safety instructions
- Manuals for additional control boards, safety modules, fieldbus modules, etc.

### Instruction and information for construction and development

- Input fuses in accordance with UL
- Programming manual for control and power unit
- Motor configurator to select the appropriate drive converter and to create downloads for parameterizing the drive converter

### Approvals and approbations

- Declaration of conformity CE
- TÜV certificate
- FS certification

### Others

- COMBIVIS, the software for comfortable parameterization of drive converters via PC (available per download)
- EPLAN drawings

## 6 Revision History

Version	Date	Description
00	2014-08	Preliminary version
01	2014-12	1st released version
02	2015-01	Fuse type class cc added to UL description
03	2015-05	Devices without internal filter registered; preface changed
04	2015-11	General technical data completely revised, power dissipation added, UL description extended
05	2017-07	Change to new CI-optics, revision of the device data, change of the overview, adjustment of the backup data
06	2018-11	230 V variant added, terminal block X1C included
07	2019-02	Leakage currents for 230V class included
08	2019-04	Reduction of leakage current < 5 mA inserted; Type code revised
09	2019-12	Adjustments of the type code, editorial changes
10	2020-11	Inserting the installation depth
11	2021-05	Insertion of the chapter "Leakage currents", editorial changes





**Austria** | KEB Automation GmbH

Ritzstraße 8 4614 Marchtrenk Austria  
 Tel: +43 7243 53586-0 Fax: +43 7243 53586-21  
 E-Mail: info@keb.at Internet: www.keb.at

**Benelux** | KEB Automation KG

Dreef 4 - box 4 1703 Dilbeek Belgium  
 Tel: +32 2 447 8580  
 E-Mail: info.benelux@keb.de Internet: www.keb.de

**Brazil** | KEB South America - Regional Manager

Rua Dr. Omar Pacheco Souza Riberio, 70  
 CEP 13569-430 Portal do Sol, São Carlos Brazil  
 Tel: +55 16 31161294 E-Mail: roberto.arias@keb.de

**Czech Republic** | KEB Automation GmbH

Videnska 188/119d 61900 Brno Czech Republic  
 Tel: +420 544 212 008  
 E-Mail: info@keb.cz Internet: www.keb.cz

**France** | Société Française KEB SASU

Z.I. de la Croix St. Nicolas 14, rue Gustave Eiffel  
 94510 La Queue en Brie France  
 Tel: +33 149620101 Fax: +33 145767495  
 E-Mail: info@keb.fr Internet: www.keb.fr

**Germany | Geared Motors**

KEB Antriebstechnik GmbH  
 Wildbacher Straße 5 08289 Schneeberg Germany  
 Telefon +49 3772 67-0 Telefax +49 3772 67-281  
 Internet: www.keb-drive.de E-Mail: info@keb-drive.de

**Italy** | KEB Italia S.r.l. Unipersonale

Via Newton, 2 20019 Settimo Milanese (Milano) Italia  
 Tel: +39 02 3353531 Fax: +39 02 33500790  
 E-Mail: info@keb.it Internet: www.keb.it

**Japan** | KEB Japan Ltd.

15 - 16, 2 - Chome, Takanaawa Minato-ku Tokyo 108 - 0074 Japan  
 Tel: +81 33 445-8515 Fax: +81 33 445-8215  
 E-Mail: info@keb.jp Internet: www.keb.jp

**P. R. China** | KEB Power Transmission Technology (Shanghai) Co. Ltd.

No. 435 QianPu Road Chedun Town Songjiang District  
 201611 Shanghai P.R. China  
 Tel: +86 21 37746688 Fax: +86 21 37746600  
 E-Mail: info@keb.cn Internet: www.keb.cn

**Poland** | KEB Automation KG

Tel: +48 60407727  
 E-Mail: roman.trinczek@keb.de Internet: www.keb.de

**Republic of Korea** | KEB Automation KG

Deoksan-Besttel 1132 ho Sangnam-ro 37  
 Seongsan-gu Changwon-si Gyeongsangnam-do Republic of Korea  
 Tel: +82 55 601 5505 Fax: +82 55 601 5506  
 E-Mail: jaeok.kim@keb.de Internet: www.keb.de

**Russian Federation** | KEB RUS Ltd.

Lesnaya str, house 30 Dzerzhinsky MO  
 140091 Moscow region Russian Federation  
 Tel: +7 495 6320217 Fax: +7 495 6320217  
 E-Mail: info@keb.ru Internet: www.keb.ru

**Spain** | KEB Automation KG

c / Mitjer, Nave 8 - Pol. Ind. LA MASIA  
 08798 Sant Cugat Sesgarrigues (Barcelona) Spain  
 Tel: +34 93 8970268 Fax: +34 93 8992035 E-Mail: vb.espana@keb.de

**Switzerland** | KEB Automation AG

Witzbergstrasse 24 8330 Pfaeffikon/ZH Switzerland  
 Tel: +41 43 2886060 Fax: +41 43 2886088  
 E-Mail: info@keb.ch Internet: www.keb.ch

**United Kingdom** | KEB (UK) Ltd.

5 Morris Close Park Farm Industrial Estate  
 Wellingborough, Northants, NN8 6 XF United Kingdom  
 Tel: +44 1933 402220 Fax: +44 1933 400724  
 E-Mail: info@keb.co.uk Internet: www.keb.co.uk

**United States** | KEB America, Inc

5100 Valley Industrial Blvd. South  
 Shakopee, MN 55379 United States  
 Tel: +1 952 2241400 Fax: +1 952 2241499  
 E-Mail: info@kebameric.com Internet: www.kebameric.com



**MORE KEB PARTNERS WORLDWIDE:**

... [www.keb.co.uk/contact/contact-worldwide](http://www.keb.co.uk/contact/contact-worldwide)



**Automation with Drive**

**[www.keb.de](http://www.keb.de)**

KEB Automation KG Suedstrasse 38 32683 Barntrup Tel. +49 5263 401-0 E-Mail: [info@keb.de](mailto:info@keb.de)